

UTV650

Maintenance Manual

SANMEN COUNTY YONGFU MACHINE CO.,LTD

Any copy or without written permission
or authorization of Yongfu is prohibited to use
the manual (version 1, Oct 2017).
All rights reserved

Foreword

This manual contains such content as introductions on overhaul, maintenance, overhauling program, dismantling, assembling, troubleshooting and service data of UTV650

This manual will help you know the vehicle better so that you can assure your customers of fast and reliable service.

This manual has been prepared on the basis of the latest specifications at the time of publication. If modifications have been made since then, differences may exist between the content of this manual and the actual vehicle.

Illustrations in this manual are used to show the basic principles of operation and work procedures. They may not represent the actual vehicle exactly in detail.

Manufacturer reserves the right of no prior notice on product improvement or modification. Repair and maintenance shall be carried out according to actual situation of vehicle.

WARNING

Inexperienced mechanics or mechanics without the proper tools and equipment may not be able to properly perform the services described in this manual.

Improper repair may result in injury to the mechanic and may render the vehicle unsafe for the rider.

GROUP INDEX	
GENERAL INFORMATION	1
PERIODIC MAINTENANCE	2
COOLING SYSTEM	3
FUEL SYSTEM	4
DRIVE TRAIN	5
STEERING SYSTEM	6
SUSPENSION SYSTEM	7
BRAKES SYSTEM	8
ELECTRICAL SYSTEM	9
TROUBLESHOOTING	10

1. GENERAL INFORMATION

PRECAUTIONS.....	1-1	TECHNICAL SPECIFICATIONS.....	1-3
TIGHTENING TORQUE.....	1-7		

PRECAUTIONS

1. Do not make engine under operation at a closed place or place with poor ventilation for a long time.
2. If engine stops operation, please do not touch it or silencer to avoid burning.
3. Due to high corrosiveness, battery fluid (dilute sulphuric acid)) may cause burns to skin and eyes. In case of splashing it to skin, please clean it with water and see the doctor immediately. In case of splashing it to clothes, please wash it with water immediately. Keep battery fluid far away from Children.
4. Cooling liquid is toxic. Do not drink it or splash it to skin, eyes and clothes. once splashing it to skin, please wash it with a lot of soapy water. In case of splashing it to eyes, please wash eyes immediately and see the doctor. In case of drinking cooling liquid, resulting in vomit, please see the doctor. Keep cooling liquid far away from children.
5. Wear proper working suit, boots and hat. If necessary, please wear long-sleeve working suit and gloves for operation.
6. Gasoline is highly inflammable. No smoking or firing. At the same time, fire sparks shall be avoided. Vaporized gasoline is explosive as well. Operation shall be carried out at places with good ventilation.
7. Battery may produce explosive hydrogen in charging. Please ensure charging at places with good ventilation.
8. Use legal parts, lubricating oil and lubricating grease.
9. Before overhauling, please clean soil and dust.
10. Keep accessories of each part well for correct assembly.
11. Replace dismantled gasket, O-shaped ring, piston pin retainer and cotter pin.
12. Retainer of rubber ring may be deformed after dismantling. So, please do not use loose and soft retainer.
13. Please wash and dry dismantled parts. Use lubricant on the surface of moving parts. For correct installation, please measure data well in dismantling process.
14. If do not know length of screw, please install screws one by one to ensure their corresponding depth.
15. Pre-tighten bolts and nuts and then tighten them with designated torque from the big to the small and from the inside to the outside.
16. Check whether rubber parts are aged. If necessary, replace them. Keep rubber parts far away from grease.
17. If necessary, special tools can be used.
18. Rotate inside and outside races of bearing to ensure flexibility of balls.
 - a) If axial or radial resistance is too large, please replace it. If there is concave-convex on the surface, please use oil for washing. If no effect is achieved with washing, please replace it.
 - b) If bearing cannot be clamped tightly in pressing into machine or axle, please replace bearing.

1. GENERAL INFORMATION

19. Please install a side dust proof bearing at correct direction. In installation of open or double-face dust proof bearing, pay attention to that marks of manufacturer shall be outward.
20. In cleaning and drying bearing, please keep bearing support still. Before installation, please carry out lubrication with oil or lubricating oil.
21. Please correct install elastic retaining ring. Assembling after opening can ensure installation of snap ring into slot.
22. After assembly, please check whether all parts are of perfect tightening and flexible movement.
23. Brake fluid and coolant may damage shell and plastic and rubber parts. In case of being splashed by them, please use water for washing.
24. In installing pipeline, please insert them to bottom of connecting pipeline. In installing pipe clamp, please install them to groove if there is. As for pipeline or pipe clamp that cannot be tightened, please replace them.
25. Do not mix soil or dust into engine and/or hydraulic braking system.
26. Before installation, please clean gasket and spacer of engine shell. Use oil stone to polish scratch of joint face evenly.
27. Do not twist or bend too much cable. Twisted or damaged cables may cause inflexible operation.
28. In assembling protective caps of parts, insert cap into groove if any.

TECHNICAL SPECIFICATIONS

Item		Parameter
Dimensions		
Overall length		2930mm
Overall width		1400mm
Overall height		1830mm
Seat height		440mm
Wheelbase		1916mm
Ground clearance		300mm
Engine		
Type		Single cylinder,four stroke,four valves,water cooling+Oil cooling ,EFI
Number of valves		4
Cylinder diameter		96 mm
Piston stroke		86 mm
Compression ratio		10.3: 1
Displacement		650cc
Maximum power		29kw/5250r/min
Maximum torque		57N.m/4250r/min
GEAR		L-H-N-R
Lubrication	Type	Lubricating system
	Type of oil	SAE10W-40/SJ
	Oil quantity	3700ml
Fuel	Type	Unleaded gasoline only 93# or higher
	Fuel pressure	350 kpa
	Fuel tank capacity	7.66 Gallons
Valve clearance	Intake	0.05 to 0.09mm
	Exhaust	0.10 to 0.15mm
Diameter of valve rod(IN)	New	4.960 to 4.975mm
	Service limit	4.930mm
Diameter of valve rod(EX)	New	4.945 to 4.965mm
	Service limit	4.930mm
Valve seat contact width(IN)	New	1.05 to 1.35mm
	Service limit	1.8mm
Valve seat contact width(EX)	New	1.25 to 1.55mm
	Service limit	2mm
Valve guide diameter	New	5.000 to 5.015mm
	Service limit	5.050mm
Free length of valve spring	New	40.5mm
	Service limit	39mm
Rocker arm bore diameter	New	12.000 to 12.018mm
	Service limit	12.030
Rocker arm shaft diameter	New	11.983 to 11.994
	Service limit	11.97mm

1. GENERAL INFORMATION

Piston measurement	Size "A"	90.955 to 90.962mm
	Size "B"	90.962 to 90.970mm
Cylinder measurement	Size "A"	90.995 to 91.003mm
	Size "B"	91.003 to 91.010mm
Clearance of cylinder - piston	New	0.033 to 0.048mm
	Service limit	0.090mm
Piston ring type	1st	Upper compression ring, rectangular
	2nd	Lower compression ring, tapered face
	3rd	Oil scraper ring
Piston ring end gap	New 1st	0.25 to 0.40mm
	New 2nd	0.35 to 0.50mm
	New 3rd	0.20 to 0.80mm
	All service limit	1.50mm
Piston/ring groove clearance	New 1st	0.03 to 0.07mm
	New 2nd	0.02 to 0.060mm
	New 3rd	0.01 to 0.045mm
	All service limit	0.15mm
Intake cam height	New	32.15 to 32.25mm
	Service limit	32.09mm
Exhaust take cam height	New	31.95mm to 32.05mm
	Service limit	31.92mm
Camshaft main bearing journal	New	34.95 to 34.975mm(Timing chain side) 21.959 to 21.980mm(Spark plug side)
	Service limit	34.94mm(Timing chain side) 21.95mm(Spark plug side)
Camshaft main bearing journal bore	New	35.000 to 35.025mm(Timing chain side) 22.000 to 22.021mm(Spark plug side)
	Service limit	35.040mm(Timing chain side) 22.040mm(Spark plug side)
Crankshaft main journal diameter	New	42.024 to 42.040mm
	Service limit	42.000mm
Crankshaft radial clearance	Service limit	0.06mm
Crankshaft deflection	Service limit	0.07mm
Crankshaft pin diameter	New	40.009 to 40.025mm
	Service limit	39.990mm
Connecting rod big end diameter	Service limit	40.100mm
Connecting rod big end radial clearance	Service limit	0.09mm
Connecting rod big end axial clearance	New	0.2 to 0.5mm
	Service limit	0.6mm
Connecting rod small end diameter	New	20.010 to 20.020mm
	Service limit	20.060mm
Piston pin diameter	New	19.996 to 20.000mm
	Service limit	19.980mm
Spark plug	Type/manufacturer	DCPR8E / NGK

1. GENERAL INFORMATION

	Gap	
Transmission type		
Continuously variable ratio		
Drive belt width	Service limit	
Gearbox type		
Gearbox oil	Capacity	
Gear ratio	H	
	L	
	R	
Capacity of cooling liquid	Type	
	Maximum load	
	Capacity of water tank	
Cooling liquid temperature thermostat	Valve opening	
	Fan opening	
Magneto generator output		
Crankshaft position sensor value of resistance		
Type		
Pressure		
Size Front		
Size Rear		
System		
Type Front		
Type Rear		
New disk thickness		
Minimum disk thickness		
Maximum disk warpage		
Operation		
Front suspension		
Rear suspension		
Front shock absorber		
Front shock absorber travel		
Rear shock absorber		
Rear shock absorber travel		
Front differential		
Front differential ratio		
Rear axle		
Rear axle ratio		
Front differential oil capacity		
Rear differential oil capacity		

Electrical		
Ignition system		EFI
Battery	Type	Maintenance Free
	Voltage	12V
	capacity	30AH
Fuses	Lock(fist shift)	10A
	Fan	20A
	Light relay	30A
	Main relay	20A
	Lock(second shift)	10A
	Reserve power	15A
	Driving lamp	10A
Head lamp		
Fog light		
Tail light		12V 21W/5W
Indicator light		
Turn light		12V 10W

TIGHTENING TORQUE

Locking devices (e.g.: locking tabs, elastic stop nuts ,self-locking fasteners ,etc.) must be installed or replaced with new ones, where specified. If the efficiency of a locking device is impaired, it must be renewed.

In order to avoid a poor assembling, tighten screws, bolts or nuts in accordance with the following recommended torque value:

Grade	Torque(N·m)					
	M6	M8	M10	M12	M14	M16
4.6	4~5	10~12	20~25	36~45	55~70	90~110
5.6	5~7	12~15	25~32	45~55	70~90	110~140
6.8	7~9	17~23	33~45	58~78	93~124	145~193
8.8	9~12	22~30	45~59	78~104	124~165	193~257
10.9	13~16	30~36	65~78	110~130	180~201	280~330
12.9	16~21	38~51	75~100	131~175	209~278	326~434

CAUTION

Be sure to use the proper tightening torque for the proper strength grade. Always torque screws, bolts and / or nuts in a criss-cross sequence.

As for important tightening torques , please refer to following standards.

Installation location	Specifications (mm)	Torque N.m(kgf.m)
Fastening bolt of engine	M10	70(7.1)
Fastening nut of suspension arm	M10	70(7.1)
Bolt of rear shock absorber	M12	80(8.2)
Bolt of front shock absorber	M10	80(8.2)
Fastening nut of wheel rim	M10	80(8.2)
Nut of wheel hub	M22	300(30.6)
Bolt of rear brake/stop pump (calipers)	M10	80(8.2)
Bolt of brake/stop disc	M8	26(2.7)
Bolt of front brake/stop pump (calipers)	M10	80(8.2)
Lock nut of steering rod	M12	80(8.2)
Lock bolt of steering gearbox	M12	140(14.3)
Bolt of exhaust pipe	M8	30(3.1)
Fastening nut of rear differential	M10	80(8.2)
Fastening nut of front differential	M10	80(8.2)
Bolt of front propeller shaft flange	M8	40(4.1)
Bolt of front propeller shaft flange	M10	80(8.2)
Bolt of rear propeller shaft flange	M10	80(8.2)
Spark plug	M12	20(2.0)
Water temperature sensor	M12	16(1.6)
Oil pressure switch	M10	12(1.2)
Adjusting nut of valve clearance	M6	12(1.2)
Main pulley bolt	M12	100(10.2)
Driven pulley bolt	M10	60(6.1)
Magneto flywheel bolt	M16	150(15.3)

1. GENERAL INFORMATION

Magneto stator bolt	M6	12.5(1.3)
One way bolt	M8	30(3.1)
Engine oil drain plug	M12	20(2.0)
Gearbox oil drain plug	M12	20(2.0)
Decompression valve plug	M22	20(2.0)
Cylinder head bolt	M10	60(6.1)
Cylinder head bolt	M6	12.5(1.3)
Connecting rod bolt	M8	50(5.1)
Timing chain wheel bolt	M8	30(3.1)
Front output shaft flange bolt	M8	30(3.1)
Rear output shaft flange bolt	M10	60(6.1)

2. PERIODIC MAINTENANCE

MAINTENANCE SCHEDULE.....	2-1	AIR CLEANER.....	2-3
VALVE CLEARANCE.....	2-4	SPARK PLUG.....	2-8
THROTTLE CABLE PLAY.....	2-8	ENGINE OIL.....	2-9
FRONT REDUCER OIL.....	2-11	REART REDUCER OIL.....	2-12
STEERING SYSTEM.....	2-12	BRAKING SYSTEM.....	2-13
GEAR SHIFT.....	2-15	COOLING SYSTEM.....	2-15
WHEELS.....	2-18	ENGINE COMPRESSION PRESSURE.....	2-18
ENGINE OIL PRESSURE.....	2-19	SUSPENSION SYSTEM.....	2-20

MAINTENANCE SCHEDULE

In order to maintain the best performance and economical performance of vehicles, suggestions on intervals for necessary regular maintenance are listed. Following maintenance is calculated in km, mile and hour based on firstly appeared data.

However, keep in mind that if the vehicle isn't used for a long period of time, the month maintenance intervals should be followed.

Items marked with an asterisk should be performed by a dealer as they require special tools and technical skills.

In case of complicated road conditions, regular maintenance shall be carried for vehicles.

ITEM	ROUTINE	Whichever Comes first ⇒	INITIAL			EVERY		
			month	1	3	6	6	12
			Km (mi)	320 (200)	1,200 (750)	2,400 (1,500)	2,400 (1,500)	4,800 (3,000)
			hours	20	75	150	150	300
Valves*	<ul style="list-style-type: none"> ● Check vale clearance. ● Adjust if necessary. 		○		○	○	○	
Cooling system	<ul style="list-style-type: none"> ● Check coolant leakage. ● Repair if necessary. ● Replace coolant every 24 months. 		○	○	○	○	○	
Spark plug	<ul style="list-style-type: none"> ● Check condition. ● Adjust gap and clean. ● Replacement every 24 months 		○	○	○	○	○	
Air filter elements	<ul style="list-style-type: none"> ● Clean. ● Replacement every 24 months 		Every 20-40 hours (More often in wet or dusty areas.)					
Crankcase breather system*	<ul style="list-style-type: none"> ● Check breather hose for cracks or damage. ● Replace if necessary. 				○	○	○	
Exhaust system*	<ul style="list-style-type: none"> ● Check for leakage. ● Tighten if necessary. ● Replace gasket(s) if necessary. 				○	○	○	
Fuel line*	<ul style="list-style-type: none"> ● Check fuel hose for cracks or damage.. ● Replacement fuel hose every 48 months ● Replacement fuel filter every 24 months 				○	○	○	
Engine oil	<ul style="list-style-type: none"> ● Replace (Check oil level every month) . 		○		○	○	○	
Engine oil filter	<ul style="list-style-type: none"> ● Replace. 		○		○		○	
Differential and gearbox oil	<ul style="list-style-type: none"> ● Check oil level/oil leakage. ● Replacement every 24 months. 		○				○	

2. PERIODIC MAINTENANCE

ITEM	ROUTINE	Whichever Comes first ⇒	INITIAL			EVERY		
			month	1	3	6	6	12
			Km (mi)	320 (200)	1,200 (750)	2,400 (1,500)	2,400 (1,500)	4,800 (3,000)
hours	20	75	150	150	300			
Brake*	<ul style="list-style-type: none"> ●Check operation/brake pad wear/fluid leakage. ●Brake fluid needs to be above the lowest position. ●Correct if necessary. Replace pads/disk if worn to the limit. 		O	O	O	O	O	
Accelerator pedal*	<ul style="list-style-type: none"> ●Check operation and free play. 		O	O	O	O	O	
Wheels*	<ul style="list-style-type: none"> ●Check balance/damage/ run out ●Repair if necessary. 		O		O	O	O	
Wheel bearings*	<ul style="list-style-type: none"> ●Check bearing assemblies for looseness or damage.. ●Replace if damaged. 		O		O	O	O	
Front and rear Suspension*	<ul style="list-style-type: none"> ●Check operation and for leakage. ●Correct if necessary. 				O		O	
Steering system*	<ul style="list-style-type: none"> ●Check operation and for looseness/Replace if damage. ●Check toe-in/Adjust if necessary. 		O	O	O	O	O	
Rear knuckle pivots and suspension arms*	<ul style="list-style-type: none"> ●Lubricate with lithium-soap-based grease. 				O	O	O	
Drive shaft universal joint*	<ul style="list-style-type: none"> ●Lubricate with lithium-soap-based grease. 				O	O	O	
Engine mount*	<ul style="list-style-type: none"> ●Check for cracks or damage. ●Correct bolt tightness. 				O	O	O	
Front and rear axle boots*	<ul style="list-style-type: none"> ●Check operation. ●Replace if damage. 		O				O	
Stabilizer bushings*	<ul style="list-style-type: none"> ●Check for cracks or damage. 				O	O	O	
Fittings and fasteners*	<ul style="list-style-type: none"> ●Check all chassis fittings and fasteners. ●Correct if necessary. 		O	O	O	O	O	
Battery	<ul style="list-style-type: none"> ●End connection 		O		O	O	O	
Lamp and steering indication	<ul style="list-style-type: none"> ●Operation 		O	O	O	O	O	

AIR CLEANER

In case of driving in dusty environment, air filter shall be cleaned regularly. It is of great possibility to accelerate wear to engine if there is not filtering element or worn filtering element is used. So, please keep air filter under good conditions all the time. If vehicle is used in dusty area, inspect more frequently than specified in MAINTENANCE SCHEDULE.

If the air cleaner is clogged with dust, intake resistance will be increased, with a resultant decrease in power output and an increase in fuel consumption. never remove or modify any component in the air filter housing. The engine management system is calibrated to operate specifically with these components. Otherwise, engine performance degradation or damage can occur. Check and clean the air cleaner element in the following manner:

Remove left and right seats, gear shift handle.



Remove engine shield.



Release 4 clamps and remove air filter housing cover.

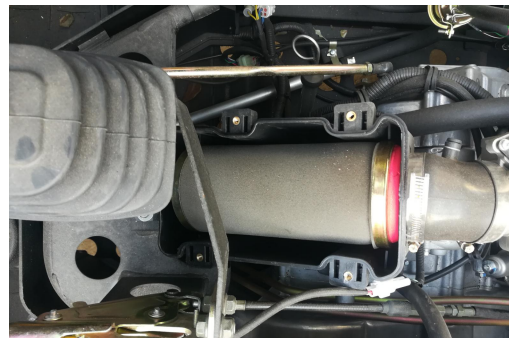

Loosen clamp and remove air filter.

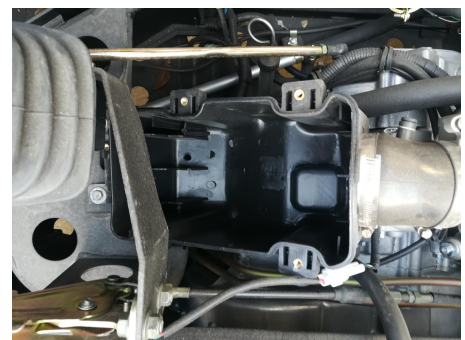

Blow low pressure compressed air on filter element to



clean it.

Properly reinstall removed parts in the reverse order of their removal. pay attention to the seal gasket of air filter housing is not skew.

CAUTION

- 1.If liquid /deposits are found, squeeze and dry the foam filter. Replace filter element if damaged.
- 2.Do not start engine if liquid or deposit are found. If there is oil in the air filter housing, check engine oil level. Oil level may be too high.
- 3.Inspect the air cleaner element for tears, a torn element must be replaced.

VALVE CLEARANCE

Excessive valve clearance results in valve noise and insufficient valve clearance results in valve damage and reduced power.

Check the intake and exhaust valve clearances at the distances indicated above and adjust the valve clearances to specification,if necessary.

Valve clearance is to be checked when the engine is cold.The intake and exhaust valves must be checked an adjusted when the piston is at TOP-DEAD –CENTER(TDC) on the compression stroke.

Remove left and right seats, gear shift handle and engine shield.



Remove spark plug cable and spark plug of both cylinders

Remove the valve cover of both cylinders

1. Distance screws
2. Valve cover

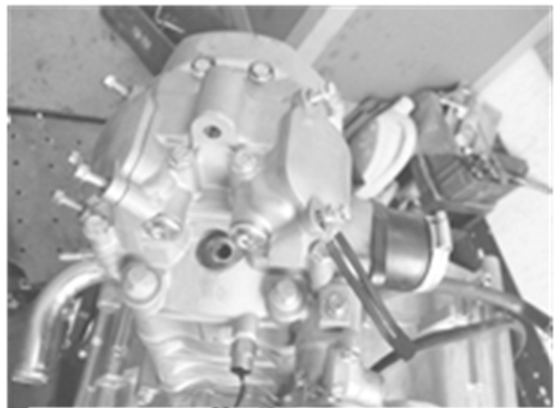

Remove the plug screw and O-ring of magneto cover.

Remove the crankshaft position sensor.

1. Crankshaft position sensor
2. Screw

Valve clearance of cylinder 2

Use a 14 mm Allen key to turn crankshaft until piston 2, rear is at TDC ignition.

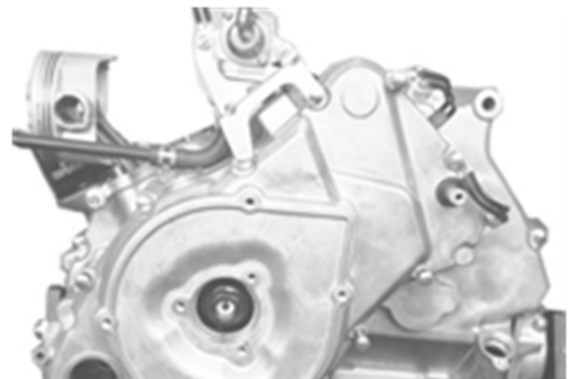

At TDC ignition, the printed marks on the camshaft timing gear have to be parallel to cylinder head base. If not, use Allen key to turn crankshaft 360°

1. Printed marks on camshaft timing gear
2. Cylinder head base



Insert the feeler gauge between the valve stem end and adjusting screw on the rocker arm to check the clearance.

If the valve clearance is out of specification, adjust valves as follows.

Valve clearance	
Intake	0.05 to 0.09mm
Exhaust	0.10 to 0.15mm

Use mean valve of exhaust/intake to ensure a proper valve adjustment.

Hold the adjustment screw at the proper position and torque the locking nut.

Repeat the procedure for each valve.

1. Adjustment screw
2. Adjustment nut
3. Feeler gauge

CAUTION

Securely tighten the locknut after completing adjustment.

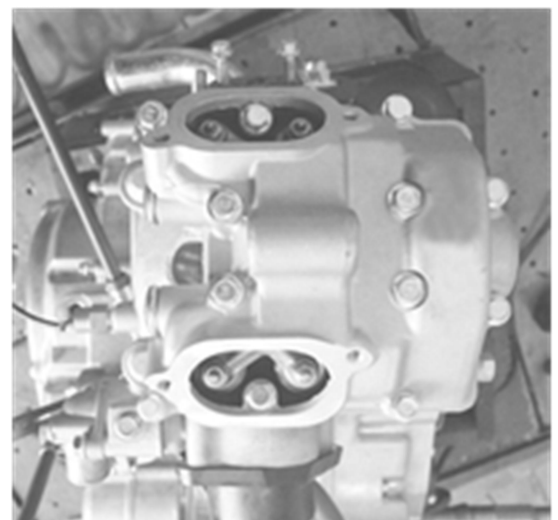

Valve clearance adjuster locknut:12N.m**Valve clearance of cylinder 1**

Using a 14 mm Allen key, turn crankshaft 280 ° counterclockwise.

1. Allen key 14mm
2. Turn crankshaft 280° counterclockwise

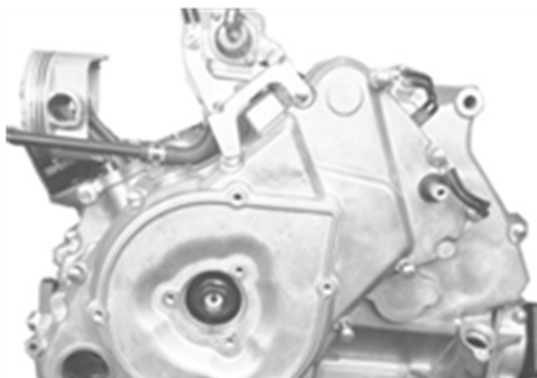

At TDC ignition, the printed marks on the camshaft timing gear have to be parallel to cylinder head base as per following illustration.

TYPICAL

1. Printed marks on camshaft timing gear
2. Cylinder head base



Insert the feeler gauge between the valve stem end and adjusting screw on the rocker arm to check the clearance.

If the valve clearance is out of specification, adjust valves as follows.

Valve clearance	
Intake	0.05 to 0.09mm
Exhaust	0.10 to 0.15mm

Use mean valve of exhaust/intake to ensure a proper valve adjustment.

Hold the adjustment screw at the proper position and torque the locking nut.

Repeat the procedure for each valve.

4. Adjustment screw
5. Adjustment nut
6. Feeler gauge

Valve clearance adjuster locknut:12N.m**CAUTION**

Securely tighten the locknut after completing adjustment.

Install the valve cover of both cylinders, spark plug cable and spark plug of both cylinders, the plug screw and O-ring of magneto cover and the crankshaft position sensor.

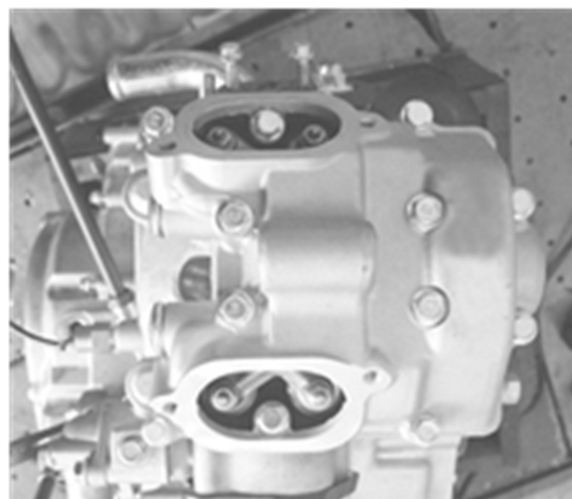
SPARK PLUG

In case of serious wear or burn to electrode or burn to insulator by spark plug or damage to thread etc, please replace it with new spark plug

In case of carbon deposit, please use proper tools for cleaning.

Spark plug gap

Use clearance gauge to measure clearance of spark plug.

In case of exceeding designated range, then adjust the gap.

Spark plug gap: 0.7-0.9mm

Spark plug heat range

Check the spark plug heat range by observing the electrode color. If the electrode of the spark plug is appearing wet or dark color, replace the spark plug with a hotter type one. If it is white or appearing glazed, replace the spark plug with a colder type one.

Standard type: DCPR8E / NGK

Colder type: DCPR9E / NGK

Hotter type: DCPR7E / NGK

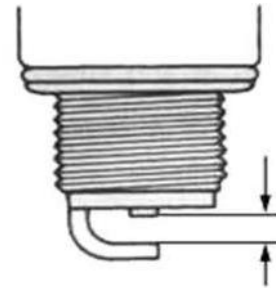

CAUTION

In order to avoid damaging cylinder cap thread, firstly use hands to tighten spark plug and then use spark plug wrench to tighten cylinder cap with designated torque.

THROTTLE CABLE PLAY

Before starting the engine, check the gas pedal to be sure it is operating correctly. Make sure the gas pedal fully returns to the idle position as soon as it is released.

Check the free play and adjust if needed. Press the throttle to make sure it moves smoothly without sticking and snaps back automatically when it is released. Check to see that the gas pedal operates correctly. It must operate smoothly and fully spring back to the idle position when released. Have a dealer repair if necessary for proper operation.

Check throttle pedal free play: 3 - 5mm

In case of out of range: → adjustment

Remove left and right seats, gear shift handle and engine shield.



Loose throttle cable (bracing cable). Turn adjuster to



adjust free play of throttle pedal.

After adjustment, tighten nut.

If free play after adjustment cannot reach designated requirement or there is viscosity for throttle valve, replace it with new throttle cable.

ENGINE OIL

Oil level verification

Strictly follow this procedure, otherwise wrong oil level may be indicated.

1. Ensure vehicle is on a level surface.
2. Start engine and let idle for a few minutes.
3. Stop engine. Wait a few minutes to allow oil to flow down to crankcase then check oil level.
4. Remove left and right seats, gear shift handle.



5. Remove engine shield



6. Remove dipstick and wipe clean stem.
7. Fully screw in dipstick to check oil level.
8. Remove dipstick and read oil level. Oil level must be between minimum(2) and maximum(1) marks on dipstick.
9. There is a capacity of 300 ml between the two marks. Refill oil as necessary. Do not overfill.
10. Reinstall dipstick.

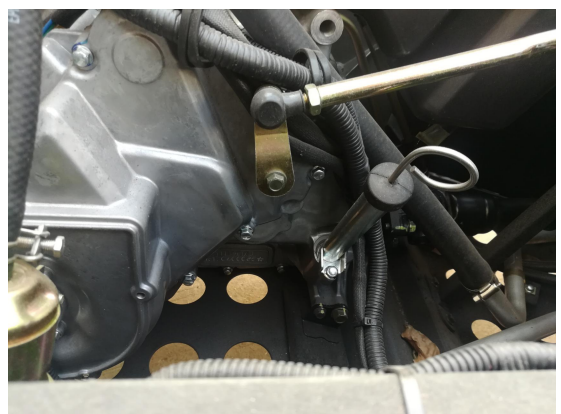

Replace engine oil

Prior to change the oil, ensure vehicle is on a level surface. Oil and oil filter must be replaced at the same time. Oil change and oil filter replacement should be done with a warm engine.

WARNING

The engine oil can be very hot. Wait until engine oil is warm.

CAUTION

Dispose oil and filter as per your local environmental regulations.

1. Ensure vehicle is on a level surface.
2. Start engine and let idle for a few minutes.
3. Stop engine. Wait a few minutes to allow oil to flow down to crankcase then check oil level.
4. Remove left and right seats, gear shift handle.
5. Remove engine shield

6. Remove dipstick.
7. Raise the vehicle, support it securely. Place a drain pan under the engine drain plug area.
8. Clean the drain plug area.
9. Unscrew drain plug then remove dipstick.
 - 1) Drain plug
 - 2) Gasket ring

10. Allow oil to drain completely from crankcase.
11. Clean the magnetic drain plug from metal shavings and residue.
12. Install a new gasket ring on drain plug. Torque drain plug to 20 N.m.

13. Remove oil filter screws, oil filter cover and oil filter.
 - 1) Oil filter screw
 - 2) Oil filter cover
 - 3) ring
 - 4) Oil filter
14. Check and clean the oil filter inlet area for dirt and other contaminations.
15. The installation is the reverse of the removal procedure. Pay attention to install a new gasket on oil filter cover.
16. Refill engine with a SAE 10W-40 API SJ classification engine oil, Oil change capacity with filter 1850mL.



there is loosening. In case of wobbling, tighten nut or dismantle steering column for further inspection.

Park vehicle at flat ground and turn handle left or right slowly to see whether it can be turned flexibly. In case of obstacles, check whether it is caused by main cable or other wiring installation. If it is not caused by above situations, please check the bottom of steering tie rod and see whether steering column bearing is damaged or not.

Park vehicle on flat ground, make sure the tire pressure for right and left tires is same and set to the proper specification, set the front wheels in the straight position, then place a load of 75kg on the seat.

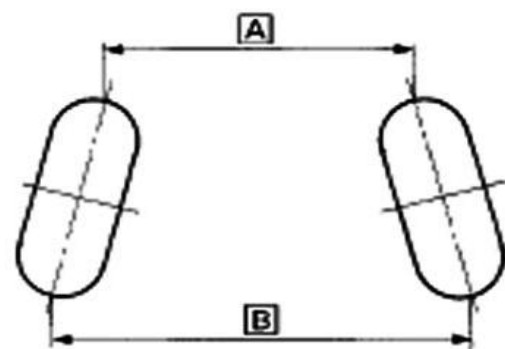

Measure the distance A and B of the front wheels and calculate the difference.

Toe-in.: $B - A = 5\text{mm}$

A: front of front wheel

B: rear of front wheel

Out of range of toe-in: → Adjust nut of tie rod

CAUTION

After adjusting toe-in, first rotate steering wheel from center position to the left and right completely, to ensure that it is the same corner, then slowly run vehicle to see whether its direction can be controlled.



BRAKING SYSTEM

Check to see if any brake fluid is leaking out of the pipe joints or the brake fluid reservoir. Apply the brakes firmly for one minute. If there is any leakage, have the vehicle inspected by an authorized dealer.

Test the brakes at slow speed after starting out to make sure they are working properly. If the brakes do not provide proper braking performance, inspect the brake system. If needed, have the vehicle inspected by an authorized dealer.

Brake fluid level

Check the brake fluid level by observing the lower limit line on the brake fluid reservoir.

When the brake fluid level is below the lower edge of sightglass, replenish with brake fluid DOT4.



Brake pedal adjustment



The brake pedal stroke is 30~40mm. If less than equal 30mm, it will be a hidden dangers, must adjust the brake pin connecting the brake pedal.

Parking brake adjustment

Pull the parking brake lever up to engage the parking brake. To release the unit, press button on front end of parking lever then push the parking lever to the bottom.



The free play is 15~20mm, the travel is 7 teeth.



If necessary, slacken the cable by loosening the locknut and screwing the adjuster on the brake holder. After adjusting the play, tighten the locknut. Or screwing the adjustment nut on the parking brake caliper



GEAR SHIFT

Check the shift lever as to change gearshift from P to R N H L and reverse smoothly. Also the meter display is correct.

The shift lever should be vertical when the gear is in neutral. If not, adjust the shift cable and then tighten the nuts of the shift cable.



COOLING SYSTEM

To prevent rust formation or freezing condition, always replenish the system with the premixed coolant or with 50% antifreeze and 50% water. Do not use tap water, straight antifreeze or straight water in the system. Tap water contains minerals and impurities which build up in the system. During cold weather, straight water causes the system to freeze while straight antifreeze thickens and does not have the same efficiency. Always use ethylene glycol antifreeze containing corrosion inhibitors specifically recommended for aluminum engines.

Cooling liquid may be reduced by natural evaporation. Regularly check horizontal position of cooling liquid

Coolant level verification

Park vehicle at flat ground and check horizontal line of cooling liquid.

Remove the upper cover of engine hood.

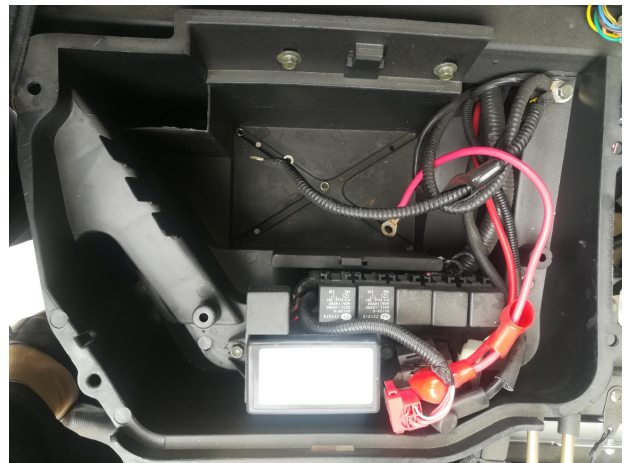

Check the level of cooling water in fluid reservoir

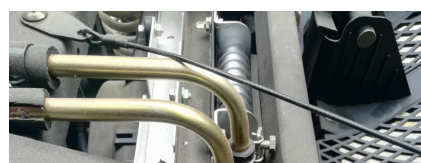

(auxiliary radiator) is between upper and lower critical levels.



WARNING

To avoid potential burns, do not remove the radiator cap or loosen the cooling drain plug if the engine is hot. Never drain or refill cooling system when engine is hot.

Coolant replacement

Park vehicle at flat ground and check horizontal line of cooling liquid.

Remove the upper cover of engine hood.



Remove radiator cap and the radiator cap.

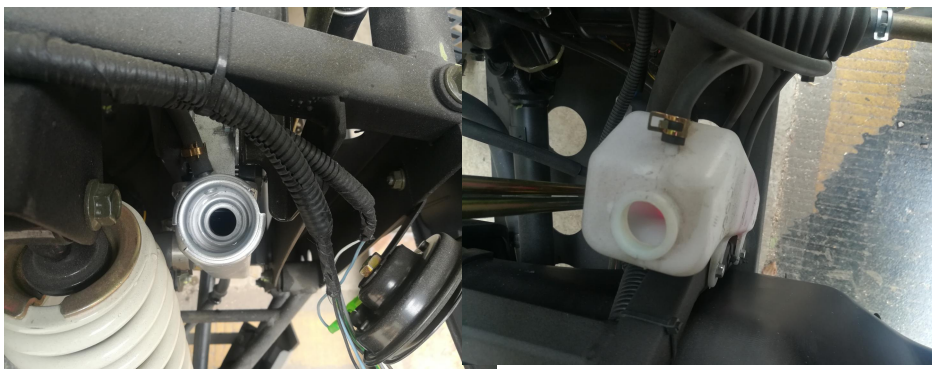

Unscrew bleed screws on top of thermostat housing.



Both cylinders must be bled.

Fill up the radiator with coolant, when the coolant comes out by the thermostat housing hole, install the bleed screws with its gasket ring and torque to 10 N.m.

Refill coolant tank up to upper level mark. Install the coolant tank cap and the radiator cap.

Run engine until radiator fan opens then stop engine.



When engine has completely cooled down, recheck coolant level in radiator and coolant tank, Top up if necessary

WHEELS

Lift wheels up at horizontal position and ensure no load to each wheel.

Shake wheels to left and right to see whether their connecting parts are installed tightly and check whether they can be swung.

No adequate tightening: → tightening

Swing: → replace rocker arm



Tire pressure

Improper tire pressure will lower comfort of operation and driving and may lead to wear to side edges of tires.

	Front wheel	Rear wheel
Rated pressure	62kPa(0.62kgf/cm ²)	62kPa(0.62kgf/cm ²)
Dimension of tire	26×9-14	26×11-14

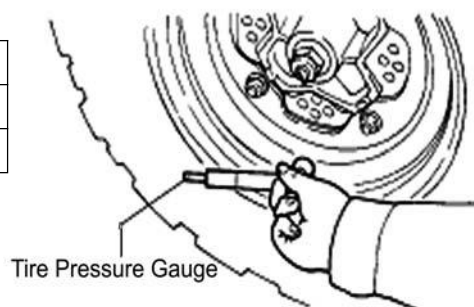

Tire thread.

When the tire groove decreases to 6 mm (0.24 in) due to wear, replace the tire.

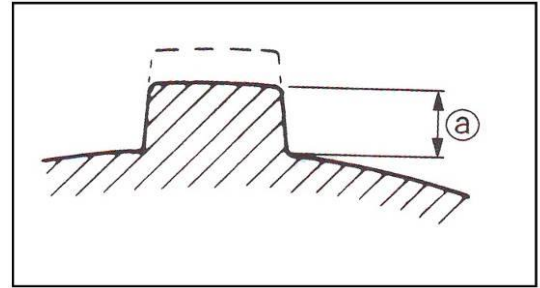
**ENGINE COMPRESSION PRESSURE**

The compression pressure reading of a cylinder is a good indicator of its internal condition. The decision to overhaul the cylinder is often based on results of a compression test.

Before measuring cylinder pressure, ensure installation and tightening of cylinder cap bolt with designated torque and reasonable clearance of valve.

Standard cylinder pressure: 0.9~1.2Mpa

Too low cylinder pressure may cause the following:

- Excessive wear to cylinder;
- Wear to piston or piston ring;
- Blockage of piston ring in groove;
- Close valve seat;
- Damage to cylinder lining or faults of other parts

Measure engine compression pressure:

1. Warm up engine.
 2. Ensure full charging of battery.
 3. Remove left and right seats, gear shift handle and engine shield
- 
4. Dismantle spark plugs.
 5. At spark plug hole, install cylinder pressure meter.
 6. Press button of start for several seconds. Record indication of maximum cylinder pressure.

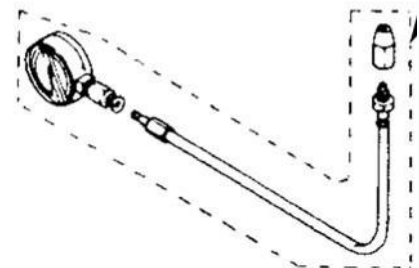
**ENGINE OIL PRESSURE**

Check the engine oil pressure periodically. This will give a good indication of the condition of the moving parts. The engine oil pressure test should be done with a warm engine 90°C and the recommended oil.

Remove left and right seats, gear shift handle and engine shield.



Install oil pressure gauge and adapter hose.
Start engine on idle speed. The engine oil pressure should be within the following values.

Oil pressure	1250 RPM	6000 RPM
Minimal	70 KPa	350 KPa
Nominal	180 KPa	420 KPa
Maximal	300 KPa	550 KPa

Remove oil pressure gauge and adapter hose.

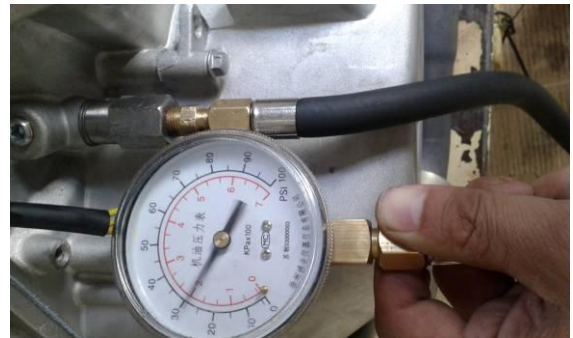

Installation oil pressure switch to 12 N.m and the oil pressure switch wire connector.
Install engine shield gear shift handle globe and left and right seats.

SUSPENSION SYSTEM

Lubricate both suspension arms with lithium-soap based grease. There are two grease fittings on each suspension arm. Check operation and for leakage.

Lubricate rear knuckles with lithium-soap based grease. There are two grease fittings on each rear knuckle.

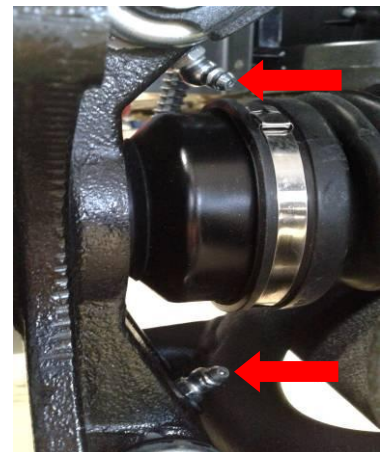

3. COOLING SYSTEM

FAULT OVERHAULING..... 3-1	COOLING SYSTEM TEST..... 3-2
THERMOSTAT..... 3-3	RADIATOR AND CAP..... 3-3
COOLANT TANK..... 3-4	RADIATOR FAN..... 3-4
WATER PUMP HOUSING..... 3-6	WATER PUMP IMPELLER..... 3-6
WATER PUMP SHAFT AND SEALS..... 3-6	

Fault overhauling

1. If cover of radiator is open and temperature of cooling liquid is over 100°C, pressure of cooling liquid will be reduced rapidly and boiled. Vapor injection may cause danger and injuries. After drop of temperature of cooling liquid, use one cloth to cover the cover of radiator and then slowly open the cover. Cooling liquid can only be tested after complete cooling.
2. Cooling liquid is toxic. Do not drink it or splash it to skin, eyes or clothes. In case of splashing cooling liquid to your eyes, use clean water to wash your eyes completely and see the doctor. In case of splashing cooling liquid to your clothes, use soapy water to wash it rapidly. In case of drinking cooling liquid, vomit will be caused immediately. Please see the internist physician immediately. Store cooling liquid well and keep it out of reach of children.
2. Check whether soil of fins is blocked or damaged. Correct curved fins. Use water and compressed air to clean soil. If damaged area reaches 20%, please replace radiator.
3. Pump overhauling can be carried out before dismantling engine.
4. Add cooling liquid to water tank. In addition to adding or exhausting cooling liquid, please do not open cover of radiator.
5. Do not splash cooling liquid to plastic parts. Once splashed, please use clean water for washing.
6. After dismantling cooling system, check leakage situation of joint.

Sharp rise of water temperature

- z Faults of radiator cover
- z There is air in cooling system.
- z Faults of water pump
- z Faults of thermostat (thermostat is not open)
- z Blockage of radiator tube or cooling tube
- z Damage or blockage to radiator
- z Incomplete cooling liquid
- z Failure or faults of fan motor

No rise or slow rise of water temperature.

- Z Faults of thermostat (thermostat is not closed)
- Z Faults of line of water temperature display

Leakage of cooling liquid

- z Faults of water seal
- z Aging, damage or improper sealing to O-shaped ring.
- z Aging, damage or improper sealing to gasket
- z Improper installation of pipe or hose
- z Aging, damage or improper sealing to pipe and/or hose

! Warning

Never start engine without coolant. Some engine parts such as the rotary seal on water pump shaft can be damaged.

COOLING SYSTEM TEST

! WARNING

To avoid potential burns, do not remove the radiator cap or loosen the cooling drain plug if the engine is hot.

Open the upper cover of engine hood and remove the radiator cap.

Install the test cap and a small hose pincher on overflow hose.

Using pressure/ vacuum pump, pressurize system to 100 kPa.



Check all hoses, radiator and cylinder(s)/base for coolant leaks or air bubbles.

Inspection

Check general condition of hoses and clamps tightness.

Check the leak indicator hole if there is oil or coolant.

NOTE: Flowing coolant indicates a defective rotary seal. Oil indicates a defective inner oil seal. If either seal is leaking, both seals must be replaced at same time. Refer to *WATERPUMP SHAFT AND SEAL* in this section.



THERMOSTAT

The thermostat is a single action type. The thermostat is located on the top of cylinder head, on intake side.

Remove:

- thermostat housing screws and pull thermostat cover

1. Thermostat cover
2. Screws

- thermostat with gasket out of the hole.

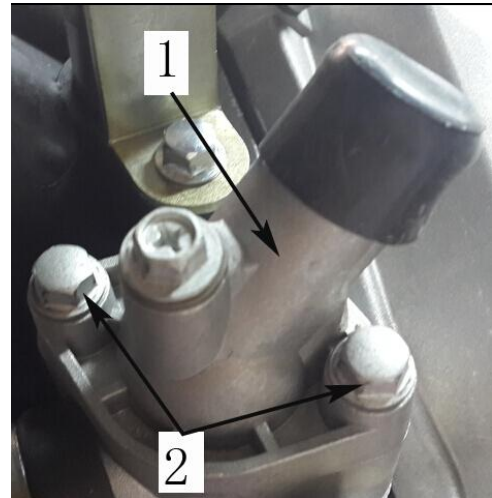

Thermostat Test

To check thermostat, put in water and heat water.

Thermostat should open when water temperature reaches 65°C (149° F).

Check if the gasket is brittle, hard or damaged. If so replace gasket.

Thermostat Installation

For installation, reverse the removal procedure, pay attention to the following details.

Install the thermostat cover then torque screws to 6N.m.

Check coolant level in radiator and coolant tank and top up if necessary.

Do not forget to bleed the cooling system. Refer to *COOLANTREPLACEMENT*.

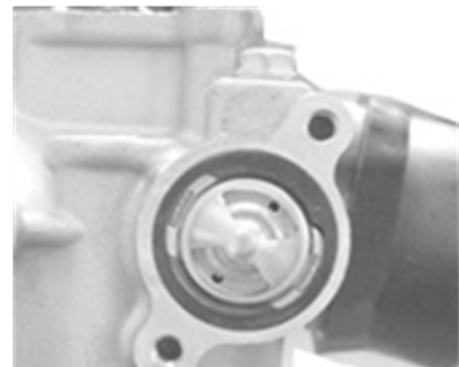

RADIATOR AND CAP

Using a pressure cap tester, check the efficiency of radiator cap. If the efficiency is feeble, install a new 100 kPa cap (do not exceed this pressure).

Radiator Inspection

Check radiating fins for clogging or damage.

Remove insects, mud or other obstructions with compressed air or low pressure water.

Radiator Removal

Drain cooling system.

Remove front fascia and radiator shroud.

Remove:

- Radiator inlet and radiator outlet hoses
- Overflow hose.
- Remove radiator.



Radiator Installation

For installation, reverse the removal procedure.

Pay attention to the following detail.

Fill up the radiator. Refer to *COOLANT REPLACEMENT*, in this section.

Check for any coolant leakage from radiator and hoses.

COOLANT TANK

The coolant expands as the temperature (up to 100-110 °C) and pressure rise in the system. If the limiting system working pressure cap is reached 110kPa, the pressure relief valve in the pressure cap is lifted from its seat and allows coolant to flow through the overflow hose into the overflow coolant tank.

Tank Removal

Remove:

- The upper cover of engine hood.
- Coolant tank support bolt and.
- Overflow hose and clamp.

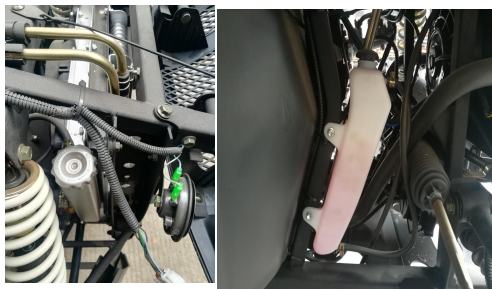

Tank Installation

The installation is the reverse of the removal procedure.

RADIATOR FAN

Radiator Fan Removal

Remove radiator shroud.

Remove bolts.

Remove the radiator fan.



Radiator Fan Test

NOTE: The ECM controls the radiator fan via the input of the coolant temperature sensor (CTS). The radiator fan should turn on when coolant temperature reaches 98 °C and should turn off when the coolant cools down at 95 °C.(203 ° F).

Connect the vehicle to B.U.D.S. Refer to ENGINE MANAGEMNT for procedure and connector location.

In ACTIVATION folder, press COOLANT FAN button.

If fan turns, check CTS, wiring harness and connectors. If all parts are good, replace the ECM.

If fan does not turn when COOLANT FAN button is pressed, use the following troubleshooting chart to resolve the problem.

Radiator Fan Installation

For the installation, reverse the removal procedure

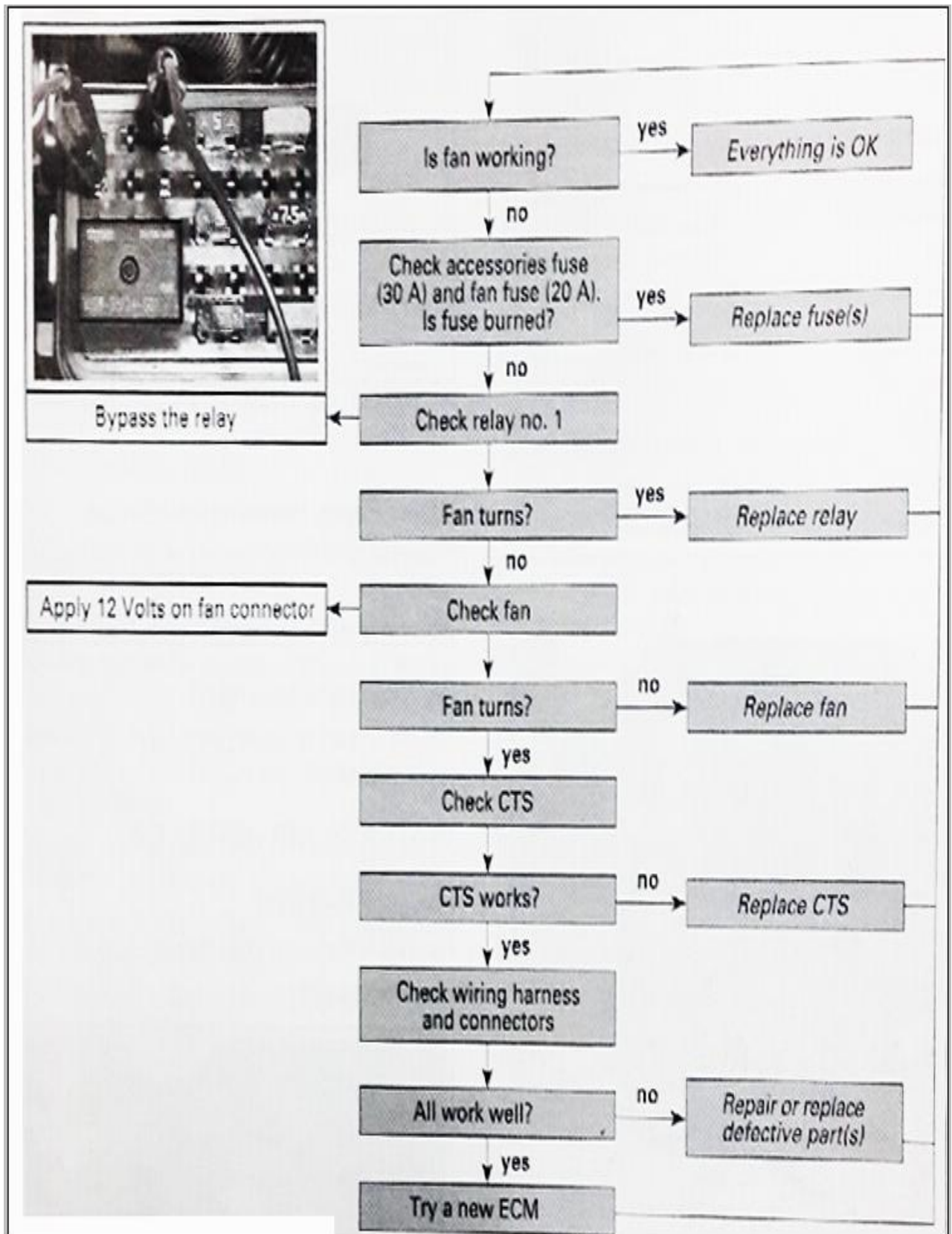

WATER PUMP HOUSING

It is located on the engine MAG side.

Water Pump Housing Removal

Drain cooling system.

Remove radiator outlet hose from water pump housing.

Remove screws retaining water pump housing.

1. Screws
2. Water pump housing
3. Sealing ring

Pull water pump housing to remove it.

! WARNING

To avoid potential burns, do not remove the radiator cap or loosen the cooling drain plug if the engine is hot .



Water Pump Housing Inspection

Check if gasket is brittle, hard or damage and replace as necessary.

1. Gasket

Water Pump Housing installation

The installation is the opposite of the removal procedure.

CAUTION: To prevent leaking, take care that the gasket is exactly in groove when you reinstall the water pump housing.

Tighten screws of water pump housing in a criss-cross sequence.

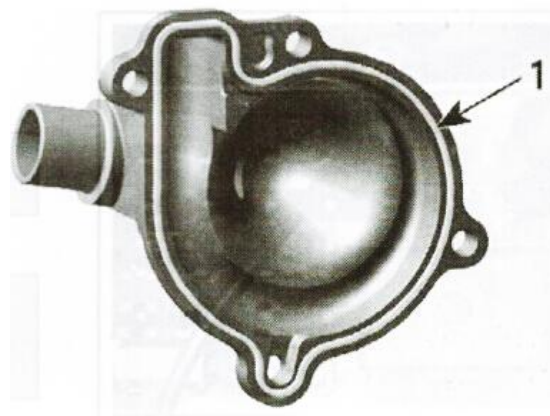

WATER PUMP IMPELLER

Impeller Removal

Remove water pump housing.

Unscrew impeller.

1. Impeller

CAUTION:

Water pump shaft and impeller have right-hand threads. Remove by turning counterclockwise and install by turning clockwise.

Check impeller for cracks or other damage. Replace impeller if damaged.

Impeller Installation

The installation is the opposite of the removal procedure. Be careful not damage impeller wings during installation.

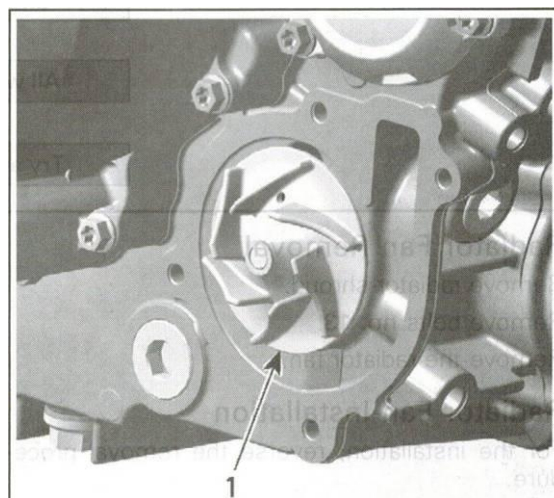

4. FUEL SYSTEM

FUEL PRESSURE TEST.....	4-2	FUEL FILTER.....	4-2
FUEL PUMP.....	4-3	FUEL TANK.....	4-3

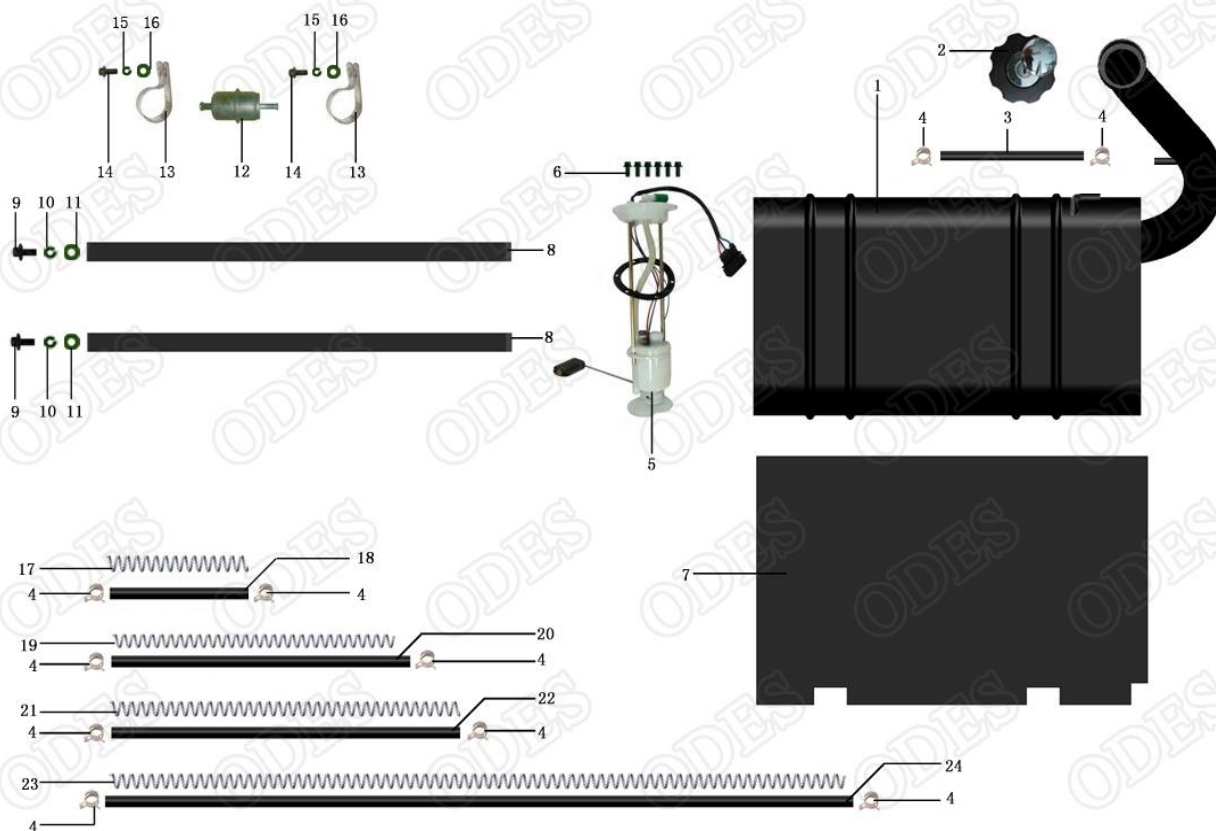

The fuel system of a fuel injection system holds much more a pressure than on carbureted vehicle. Prior to disconnecting a hose or to removing a component from the fuel system, follow the recommendation described here.

Fuel lines remain under pressure at all times. Always proceed with care and use appropriate safety equipment when working on pressurized fuel system. Wear safety glasses. Proceed with care when removing/installing pressure test equipment or disconnecting fuel line connections. Cover the fuel line connection with an absorbent shop rag. Slowly disconnect the fuel hose to minimize spilling. Wipe off any fuel spillage in the engine compartment. Do not allow fuel to spill on hot engine parts and/or electrical connectors. Never use a hose pincher on injection system high pressure hoses. Replace any damage or deteriorated fuel lines.

When the repair is completed, ensure that all hoses are connected and secured.

Always perform the fuel pressure test if any component has been removed. A pressure test must be done before turning the ignition key to ON and setting the engine stop switch to RUN. The fuel pump is activated each time in these conditions.

To locate a leak, pressurize the system. Check for leaking fuel or fuel odor. Spray soapy water on all hose connections and injectors. Air bubbles will show the leaking area.

Inspect the fuel lines, fuel tank, fuel tank cap for damage, clogging and leakage of fuel. If any damages are found, replace the defective parts with the new ones.

FUEL PRESSURE TEST

The pressure test will show the available pressure at the fuel pump outlet. It validates the pressure regulator, the fuel pump and leaks in the system.

Before proceeding to the pressure test ensure the battery is fully charged. Battery voltage must be over 12 volts. Ensure there is enough gas in fuel tank.

Remove left seat.

Disconnect outlet hose.

Install fuel pressure gauge and T-fitting between disconnected hoses.

Turn ignition key ON and set engine stop switch to RUN and observe fuel pressure. Turn ignition key off then back on. Repeat the test.

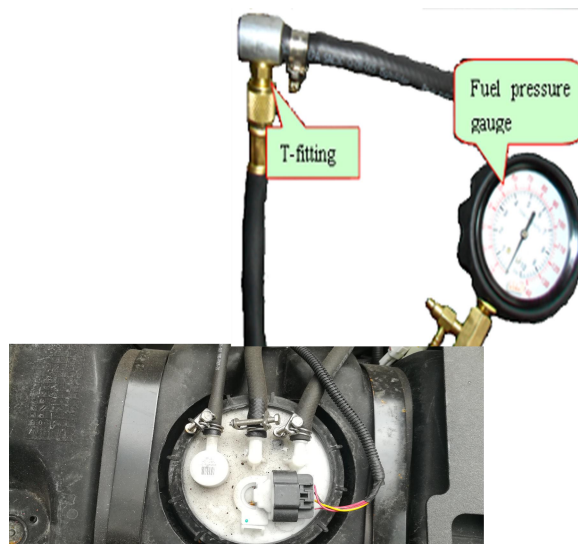

Standard fuel pressure: 350kpa.

A rapid pressure drop indicates leakage is from the fuel rail, If there is not leaking then replace fuel pump.

A slow pressure drop indicates leakage either from the fuel injector or from the fuel pressure regulator. Check fuel injector and the fuel pressure regulator for leaks. If it is not leaking then replace fuel pump module.

If no leakage, start engine and observe fuel pressure. The fuel pressure should be the same as above.

If pressure is within limits, fuel pump and the fuel pressure regulator are working adequately.

Remove pressure gauge from inlet hose. Reconnect inlet hose.

FUEL FILTER

Replace fuel filter as per amaintenance schedule.

Filter Removal

Remove oetiker clamps and pull hoses off. Detach filter from body.



Filter inspection

If fuel filter is suspected to be clogged, it may be checked as follows:

Using low compressed air, check if fuel filter is clogged. Air should flow easily through filter. In doubt, install a new filter.

Filter installation

Use arrow on filter to position it according to fuel flow.

FUEL PUMP

Fuel pump electrical test.

When turning ignition key ON, the fuel pump should run for 5 seconds to build up the fuel pressure in the system.

If the pump does not work, disconnect the connector from the fuel pump.

Install a temporary connector to the fuel pump connector. Apply 12V to this test harness.

CAUTION

Running the fuel pump a few minutes with reverse polarity can damage the pump.

If pump does not run, replace a new pump.

Other wise, check fuse and if good, probe terminals of fuel pump connector on vehicle harness or its connector, Repair or replace appropriate part.

Fuel pump removal

Remove fuel pump outlet hose and harness.

Remove fuel pump retaining screws.

Gently push pump up.

CAUTION

While pulling out the fuel pump, pay attention to fuel sensor float arm. Float arm can get stuck and bend which can reduce the fuel sensor capabilities.

Fuel pump installation

For installation, reverse the removal process but pay attention to the following.

Install a new gasket.

Pay attention to pump orientation.

Tighten retaining screws as per illustrated sequence.

Install hose properly on OUT nipples and harness.

FUEL TANK

Fuel tank draining

Never perform this operation when the engine and/or the exhaust system is/are hot.

Never sue a hose pincher on injection system high pressure hoses.

Remove fuel tank cap and siphon gas in an approved fuel container.

Fuel tank removal

Remove

Disconnect vent line from body.

Fuel tank inspection

Inspect fuel tank for any damage or cracks which may result in fuel leaks. If so replace tank with a new one.

Inspect tank and protector attachment points for damage. Inspect protector for damage.

Fuel tank installation

5. DRIVE TRAIN

FRONT DRIVE.....	5-6	REAR DRIVE.....	5-6
FRONT PROPELLER SHAFT.....	5-6	REAR PROPELLER SHAFT.....	5-6
FRONT WHEEL HUB.....	5-6	REAR WHEEL HUB.....	5-6
FRONT DRIVE SHAFT.....	5-6	REAR DRIVE SHAFT.....	5-6
FRONT DIFFERENTIAL.....	5-6	REAR DIFFERENTIAL.....	5-6
TIRES AND WHEELS.....	5-6		

FRONT DRIVE

FRONT PROPELLER SHAFT

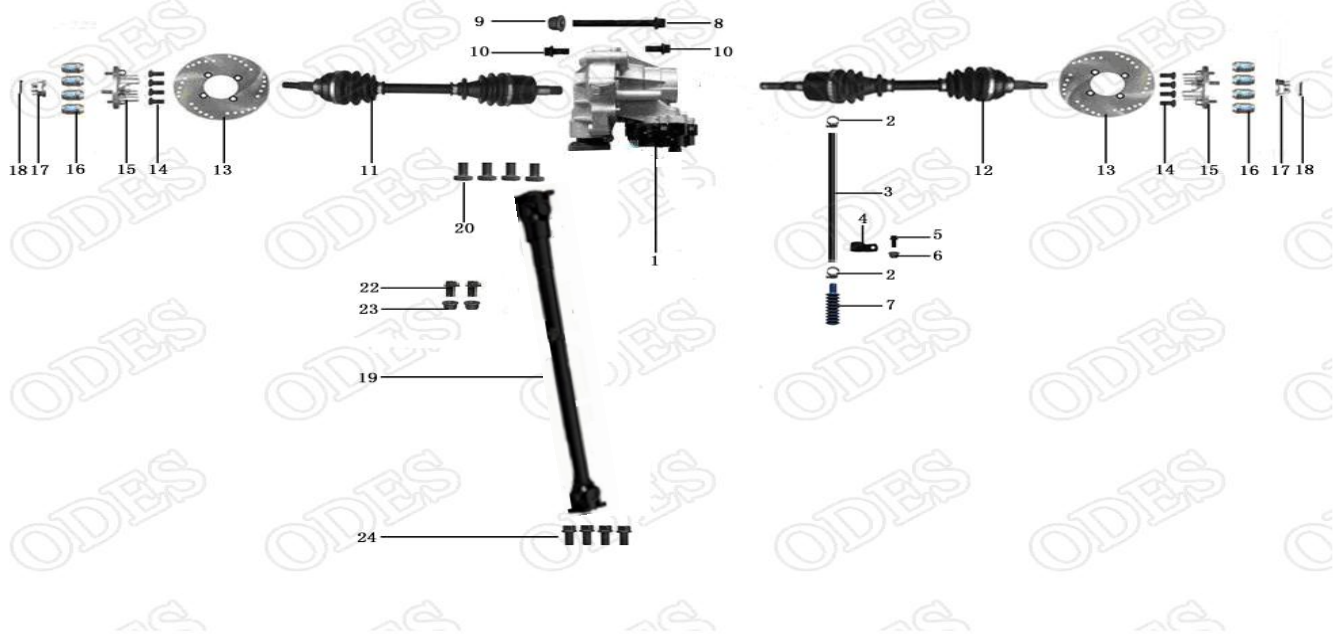

Removal

Place vehicle on PARK position and select 4WD.
 Remove left and right seats, gear shift handle and engine shield.
 Unscrew propeller shaft bolt on engine side.

Inspection

Inspect the propeller shaft for wear or damage. If any defects are found, replace the propeller shaft with new one.
 Check if U-joint moves freely in all direction.
 Check bellows for holes or brittleness.



Installation

Installation is the reverse of removal procedure.

FRONT WHEEL HUB

Removal

Raise the front of vehicle, support it securely on jack stands and remove front wheel.

Remove cotter pin, castellated nut and belleville washer.

Remove the caliper from knuckle.

Pull the wheel hub to remove it.

Inspection

Check wheel hub for cracks or other damages.

Check inner splines and wheel rim bolts for wear or other damages.

If any damage is detected on wheel hub, replace it with a new one.

**Installation**

The installation is the reverse of removal procedure. Install belleville washer so that the inside diameter protrudes outward and contacts the nut.

Tighten the castellated nut on the drive shaft end to 300N.m and further tighten until one of its grooves is aligned with a cotter pin hole. Install a new cotter pin and the wheel cap. Fold one pin of cotter pin over drive shaft end.

**FRONT DRIVE SHAFT****Removal**

Remove the appropriate wheel hub.

Remove bolt that attach the shock absorber to the upper suspension arm.

Detach upper suspension arm from knuckle.

Remove ball joint nut from knuckle.

Separate knuckle from lower suspension arm.

Move CV joint nut of knuckle then place the knuckle and the tie-rod out of way.

Remove the caliper.

Pull drive shaft out of differential.

Inspection

Inspect the condition boots. If there is any damage or evidence of leaking lubricant, replace them.

Check splines for excessive wear. Replace if necessary.

If the splines on plunging joint are worn, a check of differential inner splines should be done.

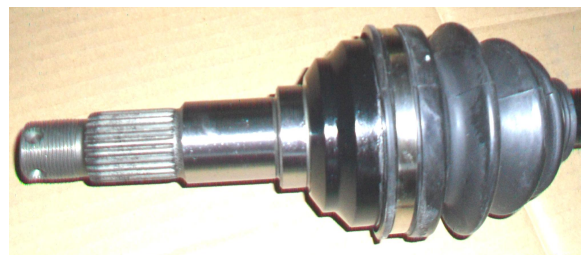

Check the ring at the end of drive shaft. If wear is apparent, replace the wear ring.



Check if the bearing in knuckle move freely and smoothly. If not, replace them.



Installation

Apply grease to the splines and insert the end of drive shaft in differential and pull joint a little to make sure that the stop ring is locked in differential side gear groove.

Insert the other end of drive shaft in the knuckle and install the knuckle to the lower suspension arm. Install and torque the ball joint retaining bolts to 45N.m

Install all other removed parts.

REAR DRIVE

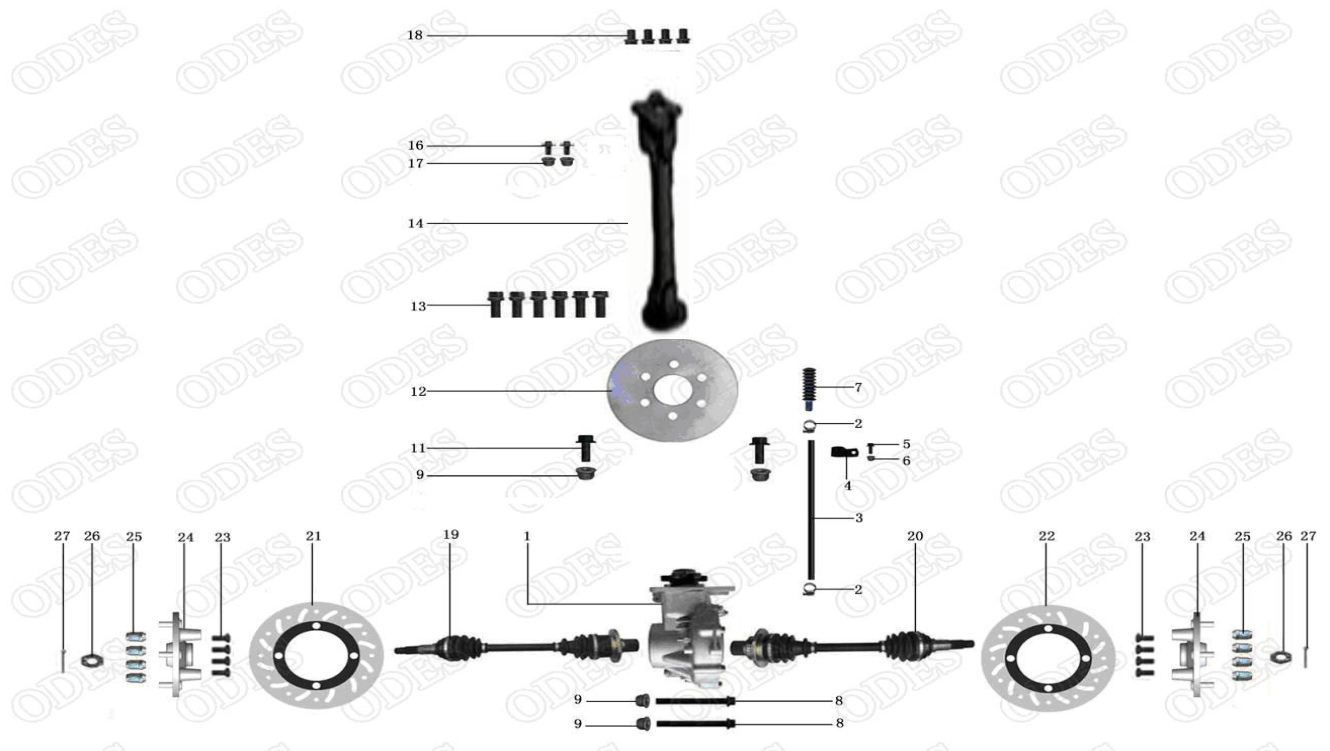

REAR PROPELLER SHAFT

Removal

Place vehicle on PARK position and select 4WD.
Remove left and right seats, gear shift handle and engine shield.
Unscrew propeller shaft bolt on engine side.

Inspection

Inspect the propeller shaft for wear or damage. If any defects are found, replace the propeller shaft with new one.
Check if U-joint moves freely in all direction.
Check bellows for holes or brittleness.

REAR WHEEL HUB

Removal

Raise the rear of vehicle, support it securely on jack stands and remove rear wheel.

Remove cotter pin, castellated nut and Belleville washer.

Remove the caliper from knuckle.

Pull the wheel hub to remove it.

Inspection

Check wheel hub for cracks or other damages.
Check inner splines and wheel rim bolts for wear or other damages.
If any damage is detected on wheel hub, replace it with a new one.

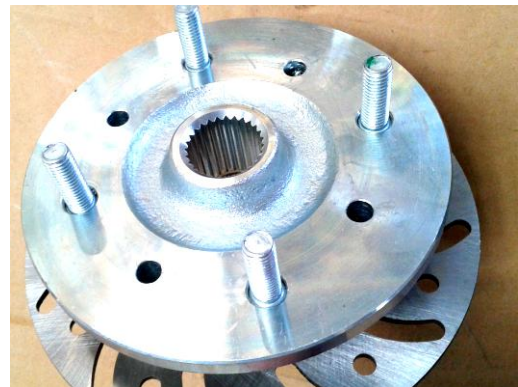

REAR DRIVE SHAFT

Removal

Remove the appropriate wheel hub.
Remove bolt that attach the shock absorber to the lower suspension arm.
Detach lower suspension arm from knuckle.
Separate knuckle from upper suspension arm.
Remove the caliper.
Pull drive shaft out of differential.

Inspection

Inspect the condition boots. If there is any damage or evidence of leaking lubricant, replace them.
Check splines for excessive wear. Replace if necessary.
If the splines on plunging joint are worn, a check of differential inner splines should be done.

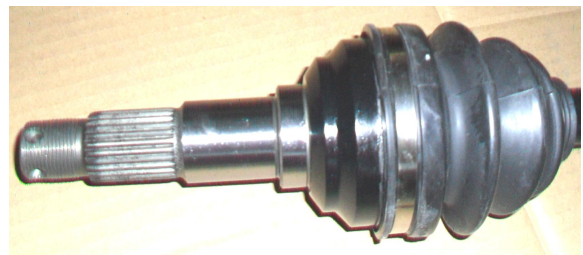

Check the ring at the end of drive shaft. If wear is apparent, replace the wear ring.

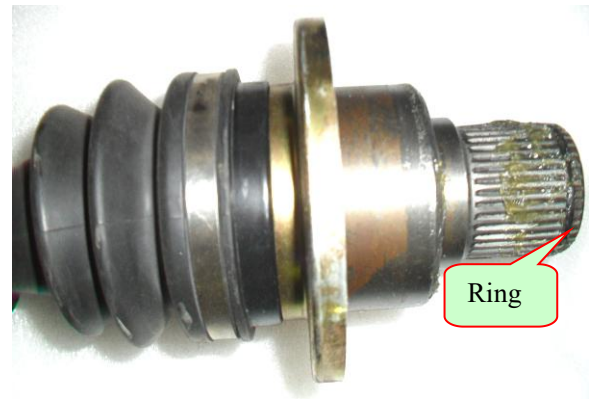

Check if the bearing in knuckle move freely and smoothly. If not, replace them.

Installation

Apply grease to the splines and insert the end of drive shaft in differential and pull joint a little to make sure that the stop ring is locked in differential side gear groove.

Insert the other end of drive shaft in the knuckle and install the knuckle to the upper suspension arm.

Install all other removed parts.



Raise rear of vehicle, support it securely on jack stands and remove rear wheels.

On both sides, remove the drive shafts.

Remove upper differential bolts, differential support bolts and lower differential bolts

Inspection

Inspect the gear case, case cover, bearing, oil seals and dust seal for wear or damage. If any damage or wear is found, replace the oil seal or dust seal with a new one.

Check back lash and drag torque.

Check the breather rubber case for wear or damage. Also, check that the joint of rubber case fits tightly.

Installation

The installation is the reverse of the removal procedure. Pay attention to refill the oil.

TIRES AND WHEELS

When the tires are replaced, never install a bias tire with a radial tire. such a combination could create handling and/or stability problems.

Dot mix tires of different size and/or de-sign on the same axle.

Front and rear tire pairs must be the identical model and manufacturer.

For unidirectional tread pattern, ensure that the tires are installed in the correct direction of rotation.

The radial tires must be installed as a complete set.

In dismantling tires, use special crowbar and rim protection device.

Tire replacement

Use jack to support vehicle and ensure its no dropping.
Remove the wheels.
After removing the air valve cap, release the tire pressure by depressing the valve.
Dismount the bead from the rim completely.

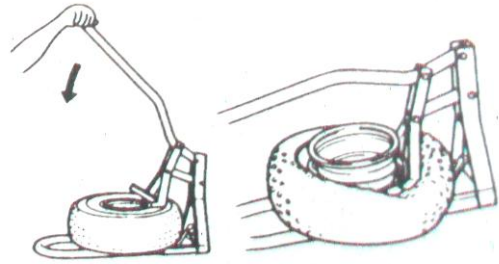

Separate the tire from the rim by using a set of tire levers and rim protectors.

CAUTION

When using the tire lever, do not scratch or hit the sealing portion of the wheel or it may cause air leakage.

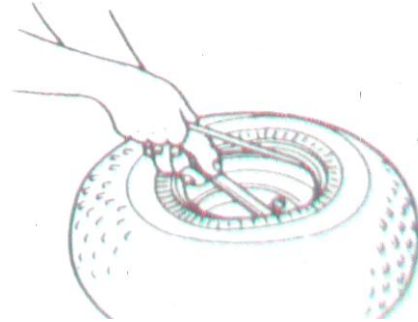

Apply tire lubricant to the new tire bead and the flange of the rim. But never apply grease, oil or gasoline to the tire bead because they will deteriorate the tire.

CAUTION

The standard tire fitted on this vehicle is AT26×9-14 for the front and AT26×11-14 for the rear.

The use of tires other than the standard may cause instability. It is highly recommended to use the specified tire.

Inspect the sealing portion of the rim for contamination and distortion before installing the

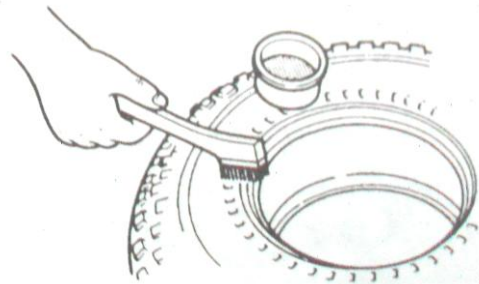

Mount the new tire on the rim.

CAUTION

When installing each tire, make sure the arrow on the tire points in the direction of rotation. Also make sure the outer side of the wheel rim is facing outward.

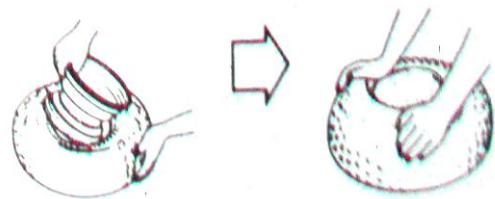

Inflate the tire to seat the tire bead.

Check the rim line cast on the tire side walls. It must be equidistant from the wheel rim all the way around. If the distance between the rim line and the wheel rim varies this indicates that the bead is not properly seated. If this is so, deflate the tire completely, and unseat the tire bead on both sides. Then coat the bead with clean water and re-seat the tire.

Adjust the tire pressure to specification.

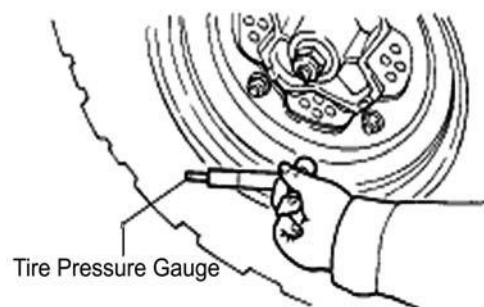

6. STEERING SYSTEM

STEERING WHEEL..... 6-1	STEERING LINKAGE..... 6-1
STEERING GEARBOX..... 6-1	STEERING ALIGNMENT..... 6-2



Inspect the tie rod for distortion or damage. If any damage are found, replace the tie rod with a new one.

Inspect the tie ends for smooth movement. If there are any abnormalities, replace the tie rod end with a new one.

Inspect the tie rod end boot for wear or damage.

If any damage are found, replace the tie rod end with a new one.

Tie rod installation

1. For the installation, reverse the removal procedure.
2. Tighten tie rod lock nuts finger tight.
3. Install tie rod on steering knuckle..
4. Torque tie rod retaining nut to 60N.m.
5. Install new cotter pins. Both ends of cotter pins must be folded around nut.



STEERING ALIGNMENT

Park vehicle on flat ground, make sure the tire pressure for right and left tires is same and set to the proper specification, set the front wheels in the straight position, then place a load of 75kg on the seat.

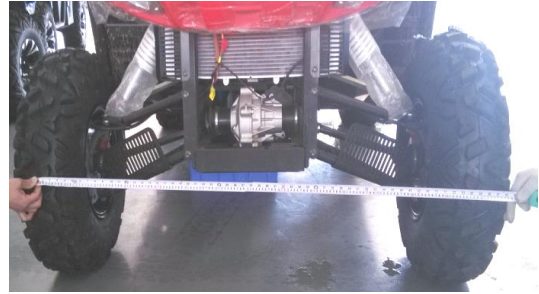

Measure the distance A and B of the front wheels and calculate the difference.

Toe-in.: $B - A = 5\text{mm}$

A: front of front wheel

B: rear of front wheel

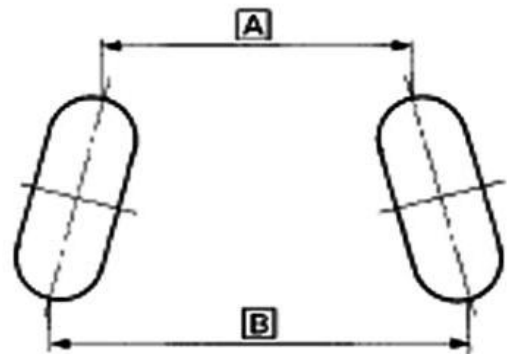

Out of range of toe-in: → Adjust nut of tie rod

CAUTION

After adjusting toe-in, first rotate steering wheel from center position to the left and right completely, to ensure that is the same corner, then slowly run vehicle to see whether its direction can be controlled.



7. SUSPENSION SYSTEM

FRONT SUSPENSION.....	7-1	REAR SUSPENSION.....	7-4
REMOVAL AND DISASSEMBLY.....	7-1	REMOVAL AND DISASSEMBLY.....	7-4
INSPECTION.....	7-2	INSPECTION.....	7-4
SHOCK ABSORBER.....	7-2	SHOCK ABSORBER.....	7-5
KNUCKLE.....	7-2	KNUCKLE.....	7-2
LOWER SUSPENSION ARM.....	7-3	LOWER SUSPENSION ARM.....	7-5
UPPER SUSPENSION ARM.....	7-3	UPPER SUSPENSION ARM.....	7-5
REASSEMBLY.....	7-3	REASSEMBLY.....	7-5

FRONT SUSPENSION

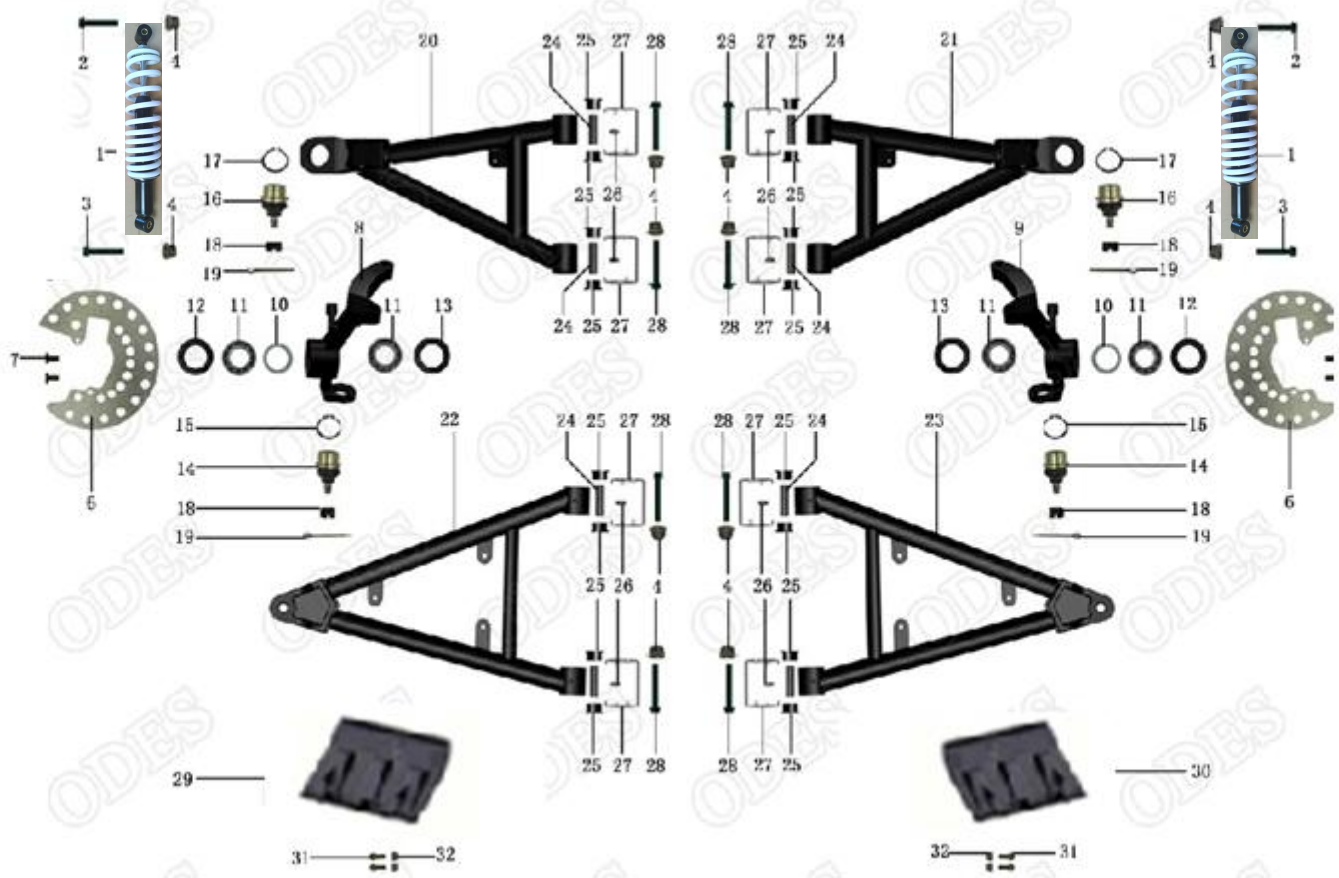

The procedure explained below is the same for the RH and LH sides unless otherwise noted. During assembly or installation, use the torque values and service products as in the torque table.

In order to prevent collapse of vehicle, please do not dismantle left and right suspensions simultaneously.

Before overhauling front suspension system, please ensure stable support of vehicle

REMOVAL AND DISASSEMBLY

Loosen wheel nut of the appropriate.

Install a jack stand under the frame to lift the front of vehicle off the ground until shock absorber is fully extended then.

Remove wheels, brake caliper and hub
remove steering knuckle from ball cage tie rod

INSPECTION

Shock absorber

Inspect the shock absorber for oil leakage or damage, inspect the bushing for wear or damage. If any damage are found, replace the front shock absorber with a new one.

Extend and compress the piston several times over its entire stroke. Check that it moves smoothly and with uniform resistance with rod up. Any of the following conditions will denote a defective shock:

- A skip or hang up when reversing stroke at mid-travel.
- Seizing or binding conditions except at extreme end of either stroke.
- A gurgling noise after completing one full compression and extension stroke.

Replace shock if any these conditions are found.



Knuckle

Inspect the knuckle for damage. If any damages are found, replace the knuckle with a new one.



Check ball joint for damage, pitting, looseness and roughness. If so, replace it.

Check ball joint bellows for cracks. Change if necessary.



Check bearing and seal for damage or wear, If any damages or wear are found, replace a new one. Rotate the inner race by hand to inspect for abnormal noise and smooth rotation.



Lower Suspension Arm

Inspect the suspension arm and for damage or distortion. If any damages or distortion are found, replace the suspension arm with a new one.

Move suspension arm from side to side. There should be no noticeable loose. Replace bushing if necessary.
Move suspension arm up and down. There should be no noticeable loose. Replace bushing if necessary.



Upper Suspension Arm

Inspect the suspension arm and for damage or distortion. If any damages or distortion are found, replace the suspension arm with a new one.

Move suspension arm from side to side. There should be no noticeable loose. Replace bushing if necessary.
Move suspension arm up and down. There should be no noticeable loose. Replace bushing if necessary.



Check ball joint for damage, pitting, looseness and roughness. If so, replace it.

Check ball joint bellows for cracks. Change if necessary.



REASSEMBLY

Reassemble and remount the front suspension in the reverse order of removal and disassembly. Pay attention to the following points.

1. Install the washers and tighten the knuckle nuts to the specified torque.
2. Replace the removed cotter pins with new cotter pins.

REAR SUSPENSION



The procedure explained below is the same for the RH and LH sides unless otherwise noted. During assembly or installation, use the torque values and service products as in the torque table

REMOVAL AND DISASSEMBLY

Loosen wheel nut of the appropriate.

Install a jack stand under the frame to lift the rear of vehicle off the ground until the shock absorber is fully extended.

Remove wheels, brake caliper and hub
remove steering knuckle from ball cage tie rod

INSPECTION

Shock absorber

Inspect the shock absorber for oil leakage or damage, inspect the bushing for wear or damage. If any damage are found, replace the rear shock absorber with a new one.

Extend and compress the piston several times over its entire stroke. Check that it moves smoothly and with uniform resistance with rod up. Any of the following conditions will denote a defective shock:

- A skip or hang up when reversing stroke at mid-travel.
- Seizing or binding conditions except at extreme end of either stroke.
- A gurgling noise after completing one full compression and extension stroke.

Replace shock if any these conditions are found



Knuckle

Inspect the knuckle for damage. If any damages are found, replace the knuckle with a new one.



Check bearing and seal for damage or wear. If any damages or wear are found, replace a new one. Rotate the inner race by hand to inspect for abnormal noise and smooth rotation

**Lower Suspension Arm**

Inspect the suspension arm and for damage or distortion. If any damages or distortion are found, replace the suspension arm with a new one.

Move suspension arm from side to side. There should be no noticeable loose. Replace bushing if necessary. Move suspension arm up and down. There should be no noticeable loose. Replace bushing if necessary.

**Upper Suspension Arm**

Inspect the suspension arm and for damage or distortion. If any damages or distortion are found, replace the suspension arm with a new one.

Move suspension arm from side to side. There should be no noticeable loose. Replace bushing if necessary. Move suspension arm up and down. There should be no noticeable loose. Replace bushing if necessary.

**REASSEMBLY**

Reassemble and remount the rear suspension in the reverse order of removal and disassembly. Pay attention to lubricate rear knuckles with lithium-soap based grease.

8. BRAKES SYSTEM

BRAKE FLUID REPLACEMENT.....	8-2	BRAKE PADS REPLACEMENT.....	8-3
BRAKE DISC.....	8-3	BRAKE CALIPER.....	8-4
BRAKE LIGHT SWITCH.....	8-4	BRAKE HOSE.....	8-5
PARKING BRAKE MECHANISM.....	8-5		

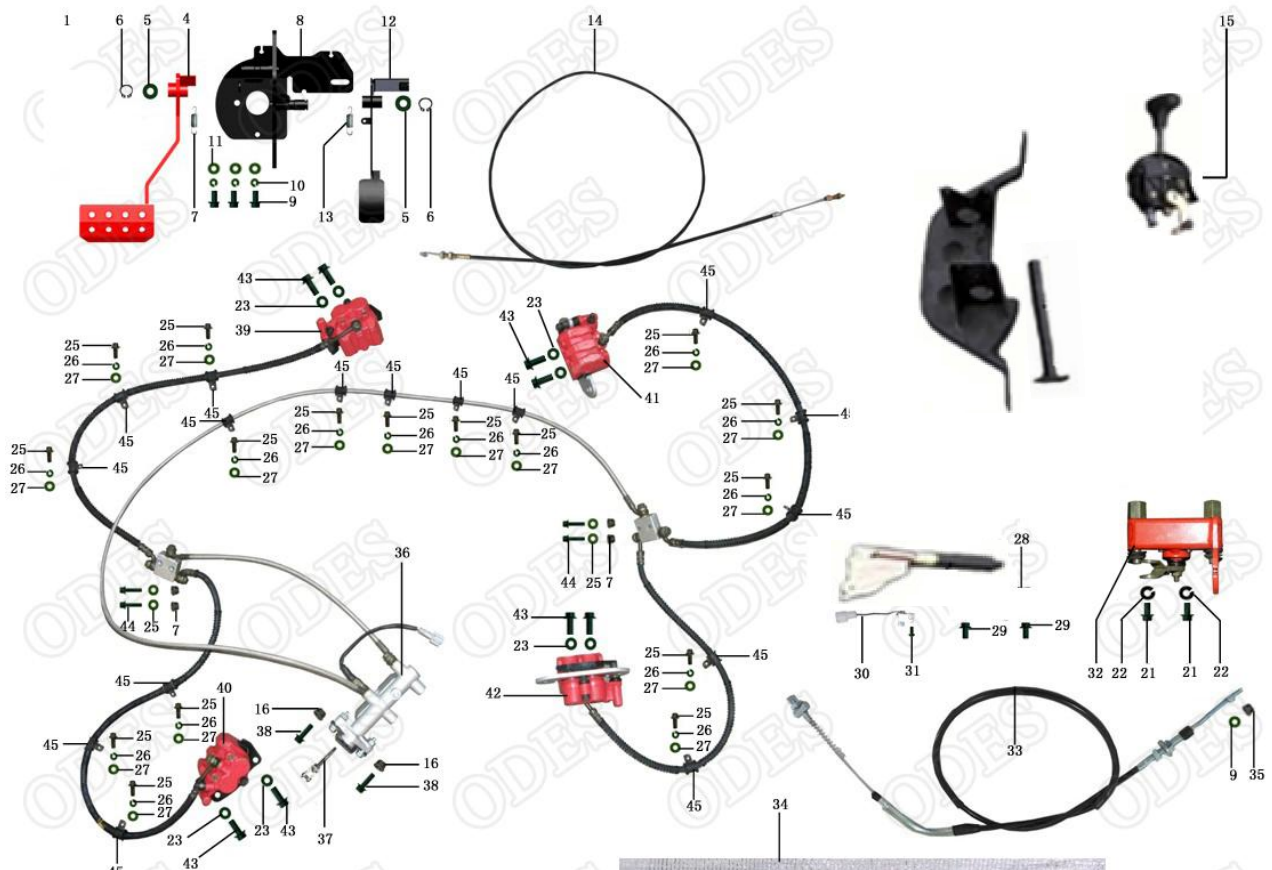

This brake system is filled with an ethylene glycol-based DOT4 brake fluid. Do not use or mix different types of fluid, such as silicone-based or petroleum-based brake fluids.

Do not use any brake fluid taken from old, used or unsealed containers. Never reuse brake fluid left over from the last servicing or which has been stored for a long periods of time.

When storing brake fluid, seal the container completely and keep it away from children.

When replenishing brake fluid, take care not to get dust into fluid.

When washing brake components, use new brake fluid. Never use cleaning solvent.

A contaminated brake disc or brake pad reduces braking performance. Discard contaminated pads and clean the brake disc with high quality brake cleaner or neutral detergent.

Brake fluid may cause damage to surfaces of plastic and rubber parts. Keep it far away from these parts.

BRAKE FLUID REPLACEMENT

Place the vehicle on a level surface.

Remove the master cylinder reservoir cap and diaphragm.

Suck up the old brake fluid as much as possible.
Fill the reservoir with new brake fluid.

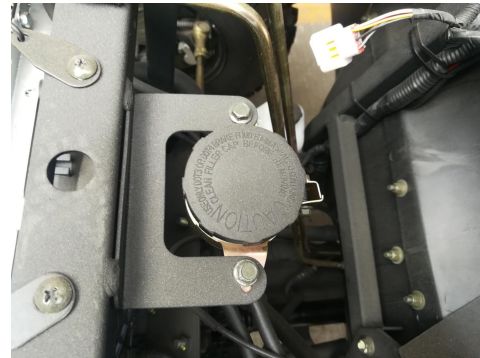

Remove the dust cap of air bleeder valve. Connect a clear hose to the air bleeder valve and insert the other end of the hose into a receptacle.

Loosen the air bleeder valve and pump the brake pedal until the old brake fluid is completely out of the brake system.



Close the air bleeder valve and squeeze and release the brake pedal several times in rapid succession and hold the pedal fully squeezed. Loosen the air bleeder valve for about quarter of a turn so that the brake fluid runs into the receptacle, this will remove the tension of the brake pedal. Then close the bleeder valve, pump and squeeze the pedal and open the valve. Repeat this process until the fluid flowing into the receptacle contains no air bubbles.

Tighten the air bleeder valve to 6N.m.

Disconnect the clear hose and install the dust cap of air bleeder valve.

Fill the reservoir with new brake fluid to the upper edge of the inspection window.

Install the master cylinder reservoir cap and diaphragm.

**CAUTION**

While bleeding the brake system, replenish the brake fluid in the reservoir as necessary. Make sure that there is always some fluid visible in the reservoir.

BRAKE PADS REPLACEMENT

Remove the wheel.



Remove the brake caliper mounting bolt and brake pads mounting pins.
Remove the brake pads.
Make sure that pad spring is in position. Install the new brake pads.
Install pad pins by pushing in the pads against pad spring to align pad slots in the pads and caliper body.
Tighten the brake pad mounting pins to 18N.m.
Tighten the brake pad mounting pins to 80N.m.

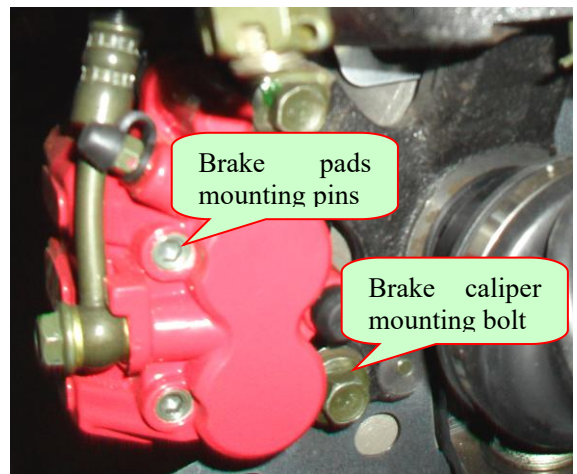

CAUTION

Do not operate the brake pedal during or after brake pad removal.

Replace the brake pads as a set, otherwise braking performance will be adversely affected.

After replacing the brake pads, pump the brake pedal a few times to check for proper brake operation and then check the brake fluid level.

BRAKE DISC

Removal and disassembly

Remove the wheel.

Remove the caliper and hub.

Remove the brake disc.

Inspection

Inspect the brake disc for cracks or damage and measure the thickness using the micrometer. If any damage are found or the thickness is less than the service limit, replace the brake disc with a new one.

Minimum thickness of front brake disc: 3.5mm.

Minimum thickness of rear brake disc: 3.0mm

Measure the warpage using the dial gauge. If the warpage exceeds the service limit, replace the brake disc with a new one.

Maximum warpage of brake disc:0.3mm.

Reassembly and remounting

Reassemble and remount the brake disc in the reverse order of removal and disassembly. Pay attention to the following points:

- Install the disc to the wheel hub with the punching letters on the disc showed up.
- Make sure that the disc is clean and free of any greasy matter.
- Apply THREAD LOCK to the brake disc bolts and tighten them to 26N.m.

BRAKE CALIPER

Removal

- Loosen wheel nuts.
- Raise vehicle and support it securely.
- Remove appropriate wheel.
- Remove the caliper bolts then the caliper. If the caliper is not being removed from the vehicle as during brake pad replacement, simply hang the caliper with a piece of wire to take the weight off the brake hose.
- If the caliper is being removed for replacement, drain brake system before removing the banjo fitting and its sealing ring. Remove the caliper from the vehicle.
- Catch spilled fluid with a rag. Attach the brake hose in a position to prevent the fluid from flowing out.

Disassembly

- Remove brake pads.
- Remove slide caliper support and pad spring.
- Place rag over piston.
- Place caliper body with piston down and apply small squirts of air pressure to the fluid inlet to remove piston.
- Remove piston seal.
- Clean piston grooves, caliper cylinder and piston with clean brake fluid.
- Clean slide pins with brake cleaner and a rag.

Inspection

- If boots are deteriorated or hard, replace with new ones.
- Check caliper cylinder for scratches, rust or other damages. If so, replace caliper.
- Check piston for scratches, rust or other damages. If so, replace caliper.

Assembly

- Coat piston seal with clean brake fluid and install it into piston grooves in caliper.
- Coat piston with clean brake fluid and install into cylinder with the closing toward caliper body.
- Apply dielectric grease into sliding bores and install slide pins.
- Install pad spring, caliper bracket and pads.

Installation

- For installation, reverse the removal procedure, pay attention to the following details:
 - Use new sealing washers when installing banjo fitting retaining brake hose to caliper.
 - Install caliper in its original position.
 - Bleed the brake system
 - Check for leaks and make sure the brakes operate normally before driving.

BRAKE LIGHT SWITCH

The brake light switch is located on the brake master cylinder. It can not be adjusted.



Inspection

First ensure brake light is good.

Check switch for dirt or corrosion. Make sure it is operating properly.

Depress brake pedal and check for brake light to turn on. Repeat with the brake pedal.

Test

Disconnect switch connectors.

Check switch operation as follows.

SWITCH POSITION	PIN		RESISTANCE
Firmly pushed	1	2	0.2 Ω max
Released			Infinite

If switch is defective, replace with a new one. If switch tests good, check wiring harness.

**Remove**

Disconnect switch connectors.

Drain brake system.

Unscrew brake light switch from master cylinder.

Catch spilled fluid with a rag.

Installation

For installation, reverse the removal procedure.

Bleed the brake system

Check for leaks and make sure the brakes operate normally before driving.

BRAKE HOSE**Inspection**

Brake hose should be inspected frequently for leaks and damages.

Check if the hoses are crushed or damaged. Any deformation can restrict the proper flow of fluid and cause braking problems.

Check hoses for cracking scrapes. This damage can cause hose failure under pressure.

When hoses are removed or disconnected, cleanliness must be observed. Clean all joints and connections before disassembly. New hoses should be cleaned with brake fluid before installation to remove any contamination.

Replace any defective parts.

Removal

Before removing any hoses, drain brake system.

Remove all necessary parts to reach the hoses.

Thoroughly clean the area around the joints that will be disconnected.

Place a pan under the joint that will be disconnected.

Disconnect any retaining clips or brackets holding the hose and remove the defective parts.

Installation

Install the new hose.

Make sure the piece will not rub against any other part.

When there is a banjo fitting securing the hose to the caliper or to the master cylinder, always replace the sealing washers with new ones.

Install any retaining clips or brackets.

Refill and bleed the brake system.

Check for leaks and make sure the brakes operate normally before driving.

PARKING BRAKE MECHANISM

Parking brake cable removal

Remove left and right seats, gear shift handle.



Remove engine shield.



Detach parking brake cable from pulley as follows:

Ensure parking brake is released.

Unscrew nut securing parking brake cable on parking brake support.

Remove cable from parking brake support.

Unhook cable from pulley.



From underneath swing arm, remove parking brake cable fasteners.



From LH side of vehicle, remove cable from vehicle.

Parking brake cable installation

The installation is the reverse of the removal procedure. However, pay attention to the following.

Adjust parking brake cable. Pull the parking brake lever up to engage the parking brake. To release the unit, press button on front end of parking lever then push the parking lever to the bottom.



The free play is 15~20mm, the travel is 7 teeth.



If necessary, slacken the cable by loosening the locknut and screwing the adjuster on the brake holder. After adjusting the play, tighten the locknut. Or screwing the adjustment nut on the parking brake caliper



9. ELECTRICAL SYSTEM

WIRING DIAGRAMS..... 9-2	CAUTIONS IN SERVICING..... 9-8
LOCATION OF ELECTRICAL COMPONENTS... 9-2	IGNITION SYSTEM.....9-8
STARTING SYSTEM..... 9-4	LAMPS..... 9-8
INDICATOR LIGHT..... 9-8	SWITCHES..... 9-8
BATTERY..... 9-8	CHARGING SYSTEM..... 9-8
RELAY.....9-6	RADIO.....9-8
MULTIFUNCTION GAUGE.....9-8	ENGINE MANAGEMENT SYSTEM..... 9-8

Overhauling information**Warning**

- < Bulb will be very hot after turning on headlamp. Please do not touch it immediately after its off. In operation, bulb needs to be cooled.
- < In warning inspection of water temperature, fire or high temperature liquid may be needed. Keep it far away from inflammables and do not to be burnt.
- < The temperature will be very high in turning of headlamp. For replacement, grease dirt will be splashed to glass in case of operation with bare hands or wearing dirty gloves. As a result, hot spots and glass deformation may be caused with damage to bulb as well.
- < Pay attention to the following in replacing bulb:
 - Do not replace bulb when it is on. Turn off ignition switch and replace it after cooling bulb.
 - In order to avoid splashing grease to glass, wear clean gloves in replacing bulb.
 - Use cloth with alcohol or banana water to clean glass to prevent any grease sticking to glass.
- < Check battery to confirm whether it is normal.
- < Regularly check switch and do not dismantle it from vehicle in inspection.
- < Cables and wires of each part need to be arranged reasonably. (→Chapter 1) For dismantling and installation of tail lamp and rear steering lamp, please refer to chapter 2.

Charging system

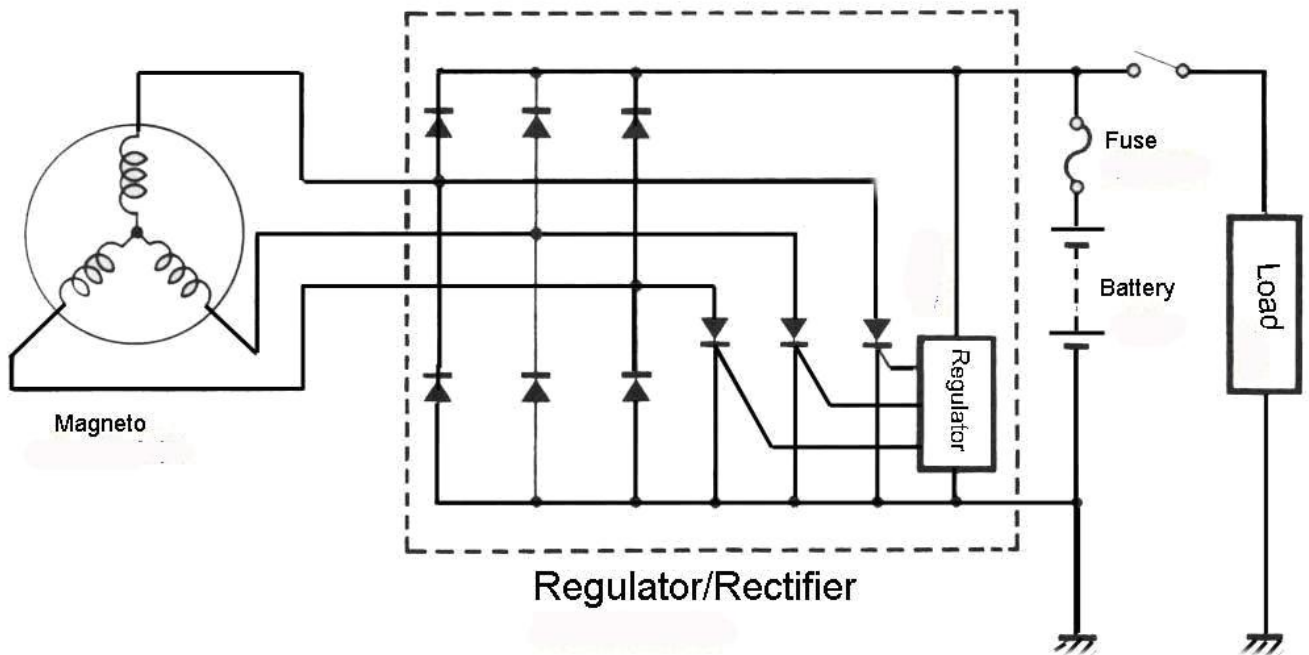

Resistance of generator coil

- Z Measure the resistance between three wires;
- Z If the resistance is not within the specified value, replace the stator coil.
- Z Check the generator core whether it is insulated. Install multimeter $1 \times 10\Omega$.

Resistance of generator coil: 0.9-1.5 Ω (color: yellow)

Insulation resistance $\infty\Omega$ (yellow - grounding wire)

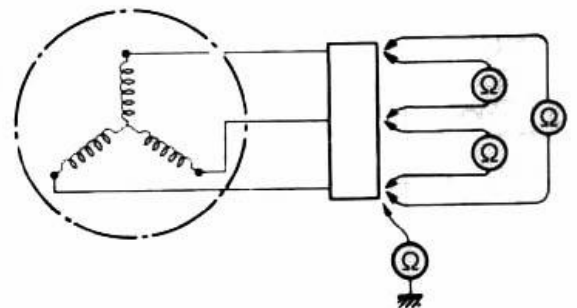

No- load performance of the generator

- Z Start the engine with the speed at 5000r/min.
- Z Measure AC voltage three wires inside the generator with the multimeter.
- Z If the voltage drops below a specified value, replace the generator.

Put the multi meter at AC step.

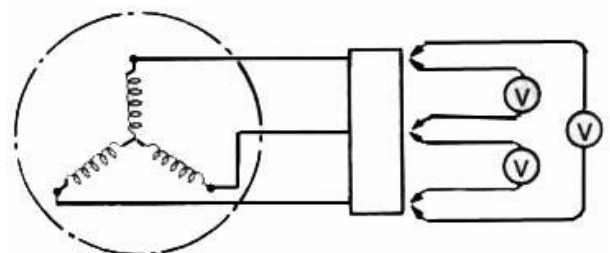

No- load performance of the generator:

> 200V (AC) at 5000r/min

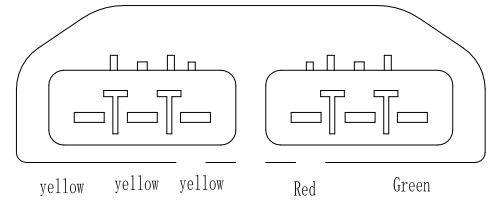
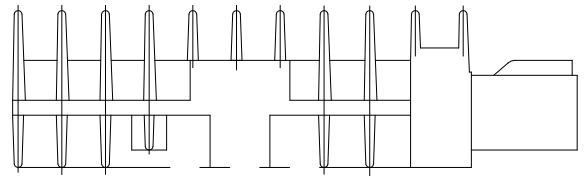
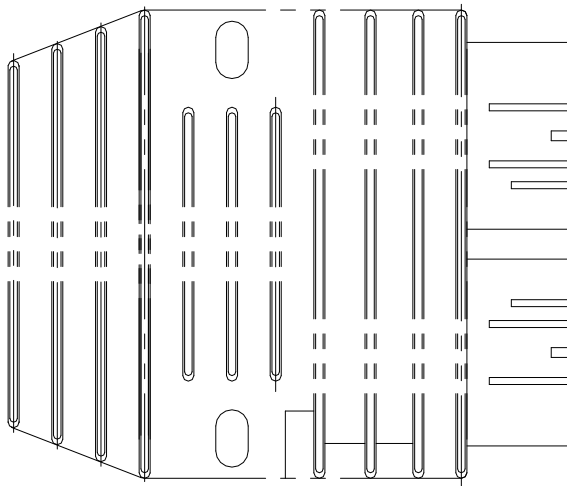

Regulator / Rectifier

- Z Measure the resistance between terminals with multimeter.
- Z If the resistance is not within the range of specified values, replace the regulator / rectifier.

NOTE:

If the probe is not connected and the multi meter reading is lower than 1.4V, replace the multi meter battery.

	Red ⊕	Yellow	Yellow	Yellow	Green	Red	Black
Black ⓘ	∞	∞	∞	∞	∞	∞	∞
Yellow	∞	∞	∞	400-500	∞	∞	∞
Yellow	∞	∞	∞	400-500	∞	∞	∞
Yellow	∞	∞	∞	400-500	∞	∞	∞
Green	∞	∞	∞	∞	∞	∞	∞
Red	400-500	400-500	400-500	750-850	∞	∞	∞
Black	∞	∞	∞	∞	∞	∞	∞

Starting system

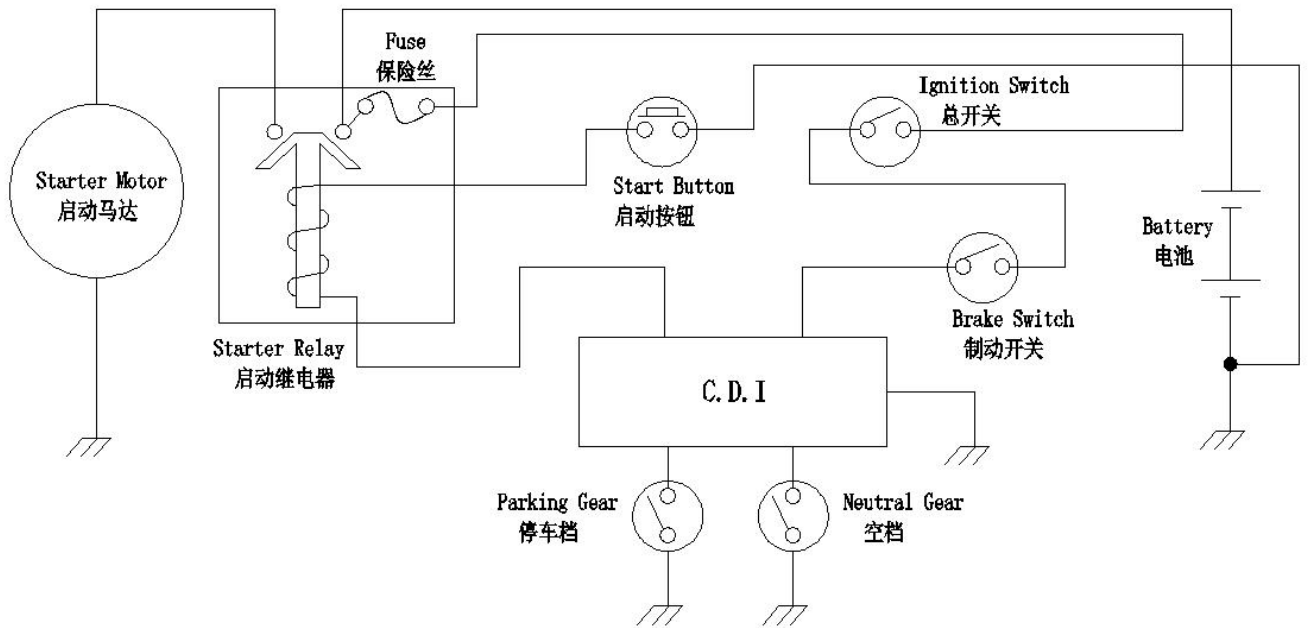

Starter motor

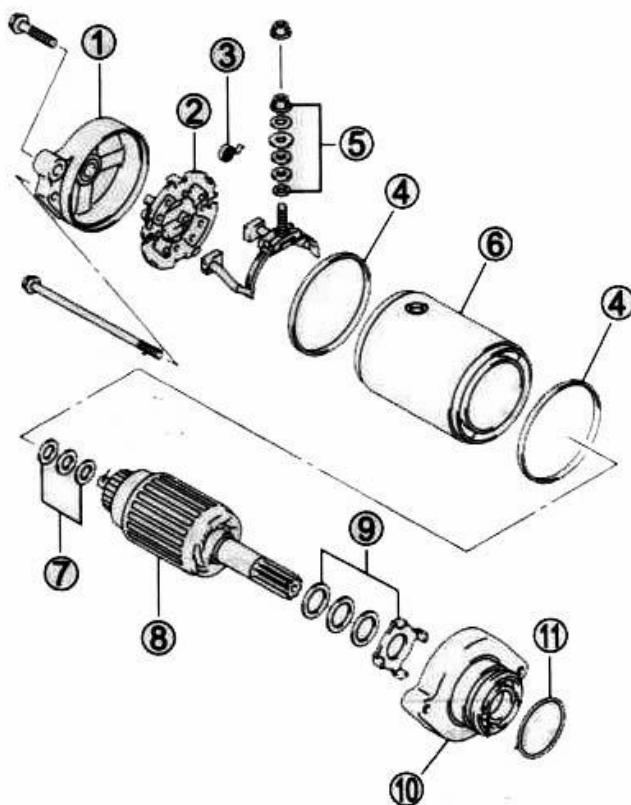

- 1 Bracket
- 2 Brush holder
- 3 Brush spring
- 4 O-Ring
- 5 Washer
- 6 Motor housing
- 7 Washer
- 8 Armature coil
- 9 Washer supporting tools
- 10 Inner bracket
- 11 O-Ring

- ① Bracket
- ② Brush Seat
- ③ Brush Spring
- ④ O-ring
- ⑤ Shims
- ⑥ Motor Housing
- ⑦ Washers
- ⑧ Armature Coil
- ⑨ Washer Kit
- ⑩ Inner Bracket
- ⑪ O-ring

Brush

- Z Check the brush on the brush holder whether it is worn abnormal, cracked or not smooth.

Worn, cracked, or not smooth: → Replace

**Rectifier**

- Z Check the rectifier whether it is discolored, abnormal wear or concave.

Abnormal wear or damage: → Replace

- Z If the rectifier is discolored, grind it with sanding paper, then wipe it with a clean fabric.
- Z If there is concave, scrape off insulator B, so that the distance with A is d.

$$d \geq 1.5 \text{ mm}$$

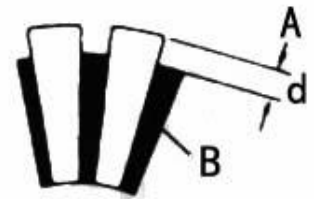
**Armature coil**

- Z Test the connection between each wire and the armature coil with the multimeter.
- Z If they are not connected, replace the armature shaft.

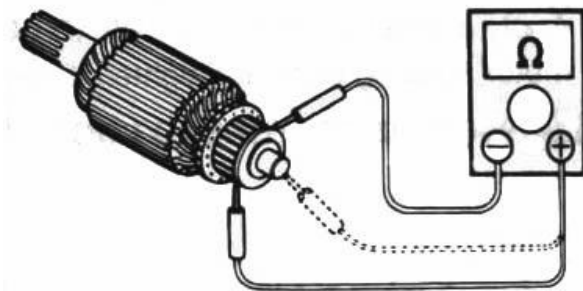
**Oil seal**

- Z Check the oil seal lip for damage or leak.

Damage or leakage: → Replace the starter motor.

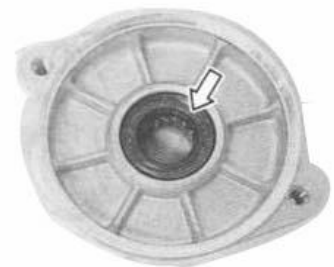

Starter relay

- Z Inter-terminal voltage is 12V. Test the direct connection of positive and negative poles with the multimeter.
- Z If the starter relay clicks and connected, the starter relay is OK.
- Z When there is no voltage of 12V, they are not connected, the starter relay is OK.

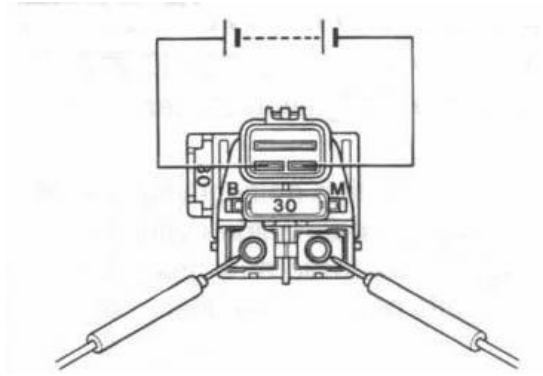

Note: Do not apply battery voltage on the starter relay for more than 2 seconds. This will result in overheating or damaging the relay coil.

- Z Measure the coil resistance with the multimeter. If the resistance exceeds the specified value, replace the starter relay.

The multimeter is set to 1x10Ω.

Starter relay coil resistance: 3-5Ω

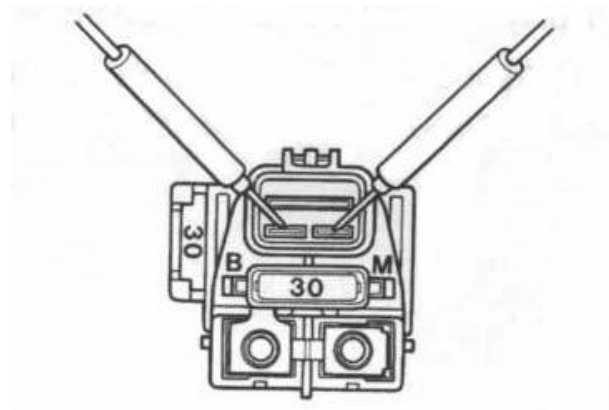
**Auxiliary starter relay**

- Z Apply 12V voltage between the positive and negative terminals of the starter relay. Test the connection between A and B with the multimeter.
- Z If the starter relay clicks and is connected, the starter relay is OK.
- Z When there is no voltage of 12V, they are not connected, the starter relay is OK.

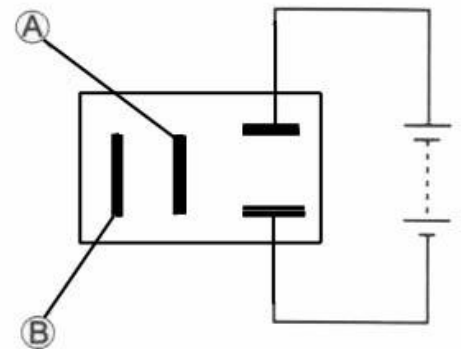

The multimeter is set to 1x10Ω.

Auxiliary starter relay coil resistance: 90-100Ω

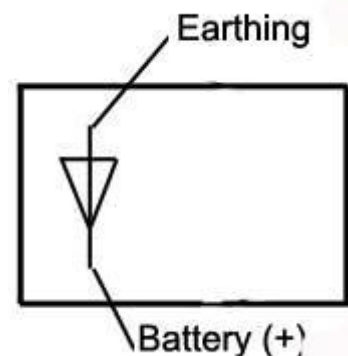

Ignition system

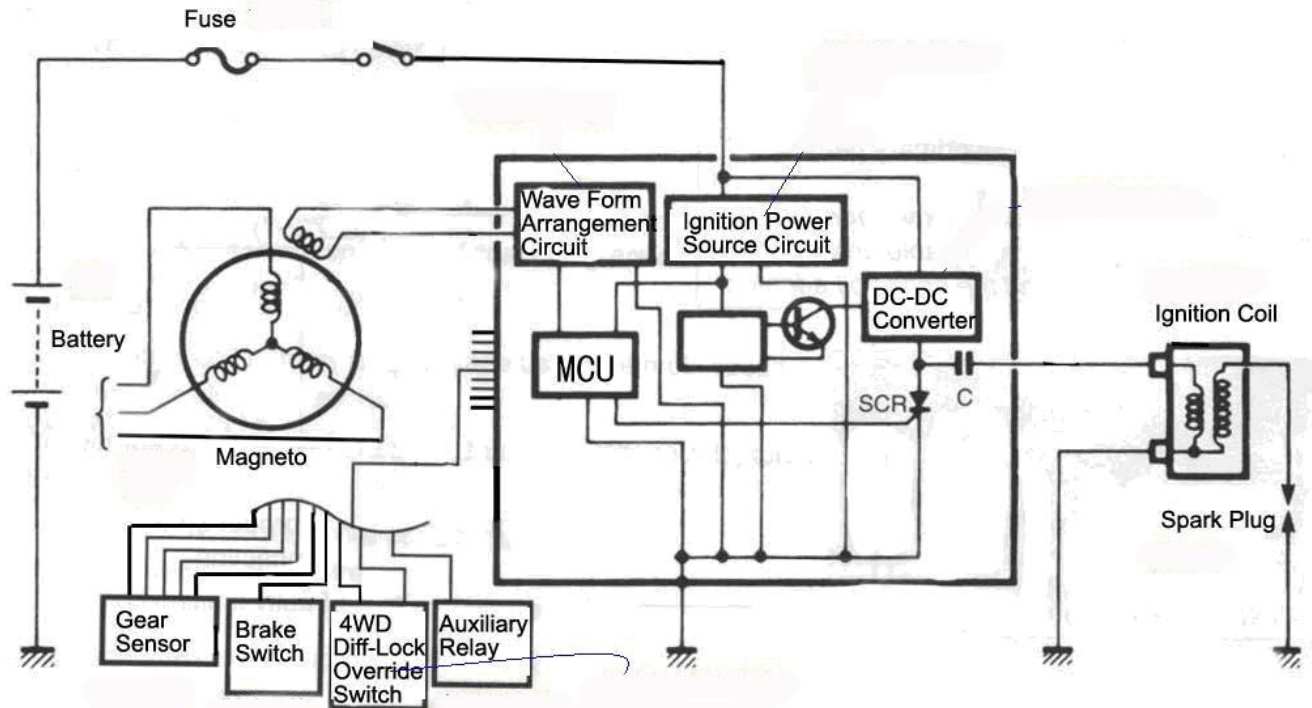

Ignition coil

Primary peak voltage of ignition coil

- Z Remove the spark plug cap as shown in the right figure. Install the new spark plug to the cap. The cylinder is connected to grounding.
- Z Connect the multimeter and the peak voltage adaptor as follows:

+Probe: Green wire or grounding wire

-Probe: Black / yellow wire

NOTE:

- Z Make sure the battery voltage $\geq 12V$. The ignition coil wires are connected.
- Z When using multi meter and the peak voltage adaptor, please refer to the user manual.
- Z Move the gear to the neutral position, turn on the ignition device.
- Z Press the start button and crank the engine for a few seconds. Then measure the primary peak voltage of the ignition coil;
- Z Repeat the steps above for several times. Measure the maximal value of the primary peak voltage.

Set the multi meter at the AC voltage position.

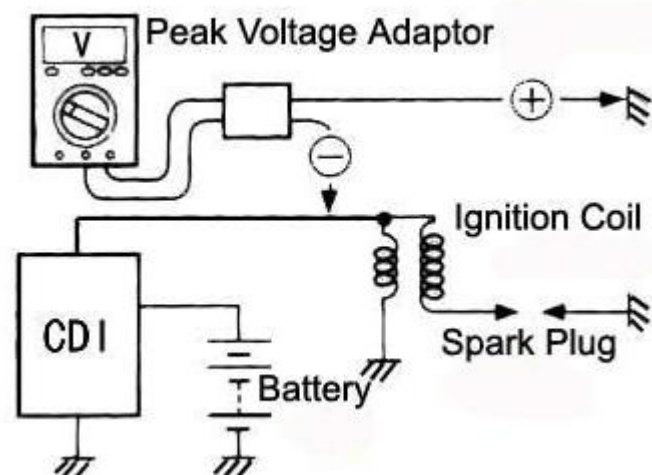

Primary peak voltage of ignition coil: $\geq 150V$

Note: Do not touch the test probes or spark plug, in case of electric shock.

- Z If the voltage is lower than the standard value, check the ignition coil and coupling coil.

Resistance of ignition coil

- Z Disconnect the ignition coil wires and spark plug cap. Remove the ignition coil;
- Z Measure the resistance of the primary and secondary windings of the ignition coil with the multimeter. If the resistance of two coils is close to the specified value, the ignition coil is in good condition.

Resistance of ignition coil

Primary winding: $0.1-1.5 \Omega$ (terminal - ground)

Secondary coil: $12-22K\Omega$ (terminal - spark plug cap)

Peak voltage of coupling coil

- Z Check the peak voltage of the coupling coil with following steps.
- Z As shown in right figure, connect the multi meter with the peak voltage adaptor.

+Probe: Green wire

-Probe: Blue wire

- Z Move the gear to the neutral position, turn on the ignition device.
- Z Press the start button and crank the engine for a few seconds, and then measure the primary peak voltage of the coupling coil;
- Z Repeat the steps above for several times. Measure the maximal value of the primary peak voltage.

Put the multi meter at AC voltage step.

Peak voltage of coupling coil: $\geq 4V$

- Z If the voltage is lower than the standard value, replace coupling coil.

Resistance of coupling coil

The multi meter is put at $1 \times 100\Omega$ step.

Resistance of coupling coil: $120-130\Omega$

- Z If the resistance is not within the specified value, replace the coupling coil.

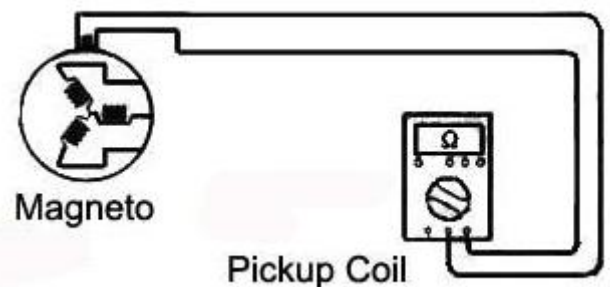
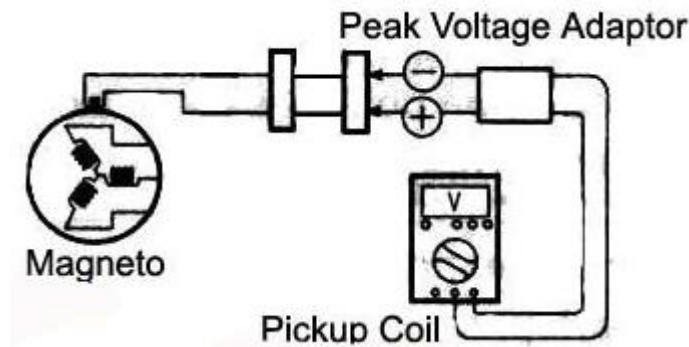
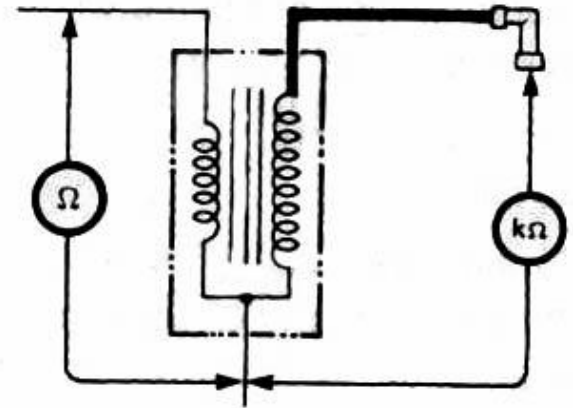

10. TROUBLESHOOTING

ELECTRICAL SYSTEM.....	10-1	COOLING SYSTEM.....	10-1
MAGNETO SYSTEM.....	10-2	LUBRICATION.....	10-2
CYLINDER AND HEAD.....	10-3	CRANKSHAFT.....	10-3
GEARBOX.....	10-3	COUPLING UNIT.....	10-4
CVT.....	10-4	ENGINE GENERAL.....	10-6

ELECTRICAL SYSTEM

Symptom: NO SPARK OR POOR SPARK

1. Refer to *ignition system*.

Symptom: STARTER DOES NOT TURN

1. Refer to starting system.

Symptom: STARTER TURNS BUT DOES NOT CRANK THE ENGINE

1. Refer to starting system.
2. Check gear condition on electric starter.
 - Worn and/or damaged starter gear. Replace electric starter and/or starter drive.
3. Check condition of starter pinion gear.
 - Worn and/or damaged starter pinion and/or ring gear. Replace starter drive and/or drive pulley fixed sheave.
4. Check splines on starter drive.
 - Poor movement of pinion gear on splines. Clean and/or replace starter drive.

Symptom: STARTER TURNS BUT STARTER DRIVE DOES NOT MESH WITH RING GEAR

1. Refer to starting system.

Symptom: STARTER KEEPS RUNNING

1. Refer to starting system.

COOLING SYSTEM

Symptom: HIGH ENGINE OPERATING TEMPERATURE

1. Check coolant level.
 - Coolant level lower than recommended. Refill(refer to cooling system).
2. Check for air bubbles in cooling system.
 - Air in cooling system. Refill and bleed cooling system (refer to cooling system).
3. Check temperature sensor for electrical/mechanical failure.
 - Temperature sensor defective. Replace.
4. Check thermostat.
 - Thermostat defective (does not open when engine gets hot). Replace (refer to cooling system).
5. Check leak indicator hole (in crankcase MAG side-water pump housing area) if coolant leaks.
 - Coolant leaking from indicator hole means a damaged water pump rotary seal. Replace rotary seal (refer to cooling system)..
6. Check condition of hoses and hose clamps fixation.
 - Hoses are brittle and/or hard. Replace.
 - Hose clamps are loose. Retighten clamps.
7. Check condition of impeller located on the water pump shaft.
 - Impeller wirings broken and/or impeller threads are damaged. Replace (refer to cooling system).
8. Check gasket on water pump housing.
 - Gasket on water pump housing leaks. Retighten screws and/or replace gasket.
9. Check cylinder head and/or cylinder base gasket.
 - Worn out gasket(s) is (are) causing coolant leakage. Replace.
10. Check coolant drain screw on water pump housing MAG side.
 - Copper ring on drain screw leaks. Retighten screw and/or replace copper ring.
11. Check intermediate gear(s) behind of PTO cover.
 - Worn out and/or broken gear(s) is/are causing less coolant supply. Replace worn out and/or broken gear(s) (refer to bottom end).

12. Check if water pump shaft is seized.
 - Water pump shaft does not turn. Replace defective part(s).
13. Check cooling fan and connection.
 - Fan motor faulty. Replace.
 - Wire harness is brittle or hard (no connection). Replace.
14. Check radiator fan switch and fuse.
 - Faulty fan switch and/or faulty fuse. Replace defective part(s).
15. Check radiator condition for leakage.
 - Radiator cracked or deformed. Replace radiator.
16. Check mud/dust in radiator fins.
 - Radiator fin obstructed, hard air cooling. Clean radiator fins.

MAGNETO SYSTEM

Symptom: BATTERY NOT CHARGING OR CHARGING VOLTAGE INADQUATE

1. Check battery
 - Battery shows less power. Reload battery.
2. Check magneto for damage and/or electrical failure.
 - Radial position of rotor wrong due to broken woodruff key. Replace woodruff key.
 - Coating on stator winding is damaged. Replace stator.
 - Resistance value is out of specification (refer to technical specifications). Replace magneto.
 - Connector on magneto is damaged and/or has electrical failure. Repair and clean contacts of connector.
3. Check voltage regulator/rectifier.
 - Refer to charging system.
4. Check wiring harness for cracks or other damages.
 - harness shows electrical failure and/or other damages. Replace/repair wiring harness.

LUBRICATION

Symptom: LOW OR NO OIL PRESSURE/HIGH OIL CONSUMPTION

1. Check oil level and search for leakage on crankcase and/or sealing parts.
 - Crankcase is leaking due to damage. Rebuild engine with new crankcase and gasket parts. Use recommended oil (refer to technical specifications).
 - Crankcase is leaking due to loose screws. Retighten screws with recommended torque
 - Sealing rings, O-rings and/or gaskets are brittle, hard or damaged. Replace damaged parts.
 - Piston rings worn out (blue colored engine exhaust emission). Replace piston rings (refer to cylinder and head).
 - Piston rings are broken (low compression). Replace piston rings (refer to cylinder and head).
 - Valve stem seal damaged and/or sealing lip is hard and/or brittle. Replace all valve stem seals.
2. Check oil filter for contamination.
 - Oil filter clogged. Replace oil and oil filter at the same time. Use recommended oil (refer to technical specifications).
3. Check oil drain plug on engine bottom.
 - Plug is loose and/or gasket ring is missing. Retighten the plug and/or place gasket ring.
4. Check leak indicator hole if oil leaks (in crankcase MAG side-water pump housing area).
 - Oil leaking from leak indicator hole means a damaged oil seal on water pump shaft. Replace oil seal (refer to cooling system).
5. Check oil pressure switch function.
 - Oil pressure switch damaged. Replace oil pressure switch.
6. Check oil orifice(s) on the oil pump suction side.
 - Oil orifice(s) is (are) clogged. Clean from contamination. Replace oil and oil filter if necessary (refer to maintenance or lubrication system).
7. Check oil pump function.
 - Oil pump rotor is out of wear limit. Replace oil pump (refer to lubrication system).
 - Oil pump seized due to oil leakage and/or air inclusion. Replace oil pump (refer to lubrication system).
 - Gears driving oil pump are broken or otherwise damaged. Replace gears.
 - Incorrect oil being used. Use recommended oil (refer to technical specifications).
8. Check oil pressure regulator valve (spring) function.

- Valve spring damaged (valve always open). Replace spring.
 - Valve piston is worn or broken. Replace valve piston (refer to lubrication system).
 - Valve piston stays open due to contamination. Clean or repair valve piston.
9. Check plain bearings in crankcase for heavy wear.
 - plain bearings out of specification (increased clearance). Replace plain bearings (refer to bottom end).
 10. Check engine oil strainer in crankcase.
 - Oil strainer is clogged due to contamination. Clean or replace strainer and diagnose causes. Replace possible damaged parts (refer to bottom end).

Symptom: OIL CONTAMINATION (white appearance)

1. Check leak indicator hole (in crankcase MAG side-water pump housing area) if water and oil leaks.
 - Leakage of oil/water mixture from indicator bore means damaged water pump seal ring and rotary seal. Replace sealing ring, rotary seal and change oil, oil filter and/or coolant (refer to lubrication system, cooling system and bottom end).
2. Check cylinder head and/or cylinder base gasket..
 - Gasket damaged or leaking. Retighten cylinder head with recommended torque and/or replace gasket.
3. Check tightening torque of cylinder head screws.
 - Screws not properly tightened. Retighten screws to recommended torque and replace oil.
4. Check oil for particles (may indicate possible engine internal damages).
 - Oil contamination due to metal or plastic particles. Replace possibly damaged part(s) including oil and oil filter. Use recommended oil (refer to technical specifications).

CYLINDER AND HEAD

Symptom: UNUSUAL ENGINE NOISE AND/OR VIBRATION

1. Check noise coming from cylinder head area.
 - Improper valve clearance adjustment. Readjust valve clearance and/or replace defective part(s).
 - Faulty chain tensioner. Replace spring and/or mechanism.
 - Chain guide worn out. Replace chain guide.
 - Stretched chain and/or worn out sprockets. Replace chain and sprockets.
 - Sprocket screws got loose. Retighten screws with recommended torque.
 - Rocker arm(s) is (are) worn out (valve adjustment). Readjust valve clearance and/or replace rocker arm(s).
 - Incorrect camshaft timing adjustment. Replace damaged components and readjust camshaft timing (refer to cylinder and head).

Symptom: OIL CONTAMINATION ON CYLINDER AND/OR HEAD

1. Check screws for torque.
 - Loose screws. Retighten screws with recommended torque.
 - Gaskets are brittle, hard, worn out or otherwise damaged. Replace damaged gaskets, O-rings or the V-ring on breather.

CRANKSHAFT

Symptom: UNUSUAL ENGINE NOISE AND/OR VIBRATION

1. Check noise coming from crankshaft area..
 - Crankshaft plain bearings are damaged,. Replace crankshaft plain bearings.
 - Connecting rod plain bearings are damaged. Replace connecting rod plain bearings.
 - Magneto rotor got loose. Replace damaged components and retighten rotor retaining screw with recommended torque (refer to MAGNETO SYSTEM).

GEARBOX

Symptom: UNUSUAL GEARBOX NOISE AND/OR VIBRATION

1. Check oil level in gearbox.
 - Oil leakage from gearbox. Replace damaged gasket(s) and/or oil seal(s), torque screws and refill with oil up to specified level (refer to TECHNICAL SPECIFICATIONS and GEARBOX)
2. Check bearings in the gearbox for free movement.
 - Bearing(s) do(es) not move freely. Replace bearing(s)
3. Check for knocking noise.

- Tooth of gears are damaged and/or worn. Replace respective gears.

Symptom: GEAR INDICATION FAILS.

1. Check contact screws on gear housing center.
 - Check contact screw outside for contamination and wetness. Clean contact screw and screw for wiring harness.
 - Contact(s) is (are) corroded and/or contact screw for wiring harness got loose. Clean contact surface and retighten contact screw(s) with recommended torque.
 - Wiring harness has broken cables. Replace wiring harness.
 - Shifting indicator switch(es) pin(s) is (are) worn and/or damaged. Replace shifting indicator switch(es).

Symptom: GEAR(S) IS (ARE) HARD TO SHIFT

1. Check shift shaft splines and/or shift forks for wear and/or damages.
 - Shift shaft is worn out and/or shows damaged splines. Replace shift shaft.
 - Shift drum track(s) and/or splines is (are) worn out or damaged. Replace shift drum and damaged part(s).
 - Shift fork(s) is (are) worn out and/or engagement pins are damaged. Replace shift fork(s).
 - Shift fork(s) is (are) worn out and/or fork(s) is (are) damaged. Replace shift fork(s).
 - Shift gear(s) is (are) worn out. Replace shift gear(s).
 - Shifting indicator switch(es) pin(s) is (are) worn out (no rounding on top of pin). Replace shifting indicator switch(es).
2. Check engine idle speed.
 - Check throttle cable and throttle adjustment.
 - Check bypass idle valve and connectors.
3. Check CVT one way clutch on drive pulley.
 - CVT one way clutch was not lubricated correctly. Lubricate CVT one way clutch (refer to CONTINUOUSLY VARIABLE TRANSMISSION (CVT)).
 - CVT one way clutch is worn out or damaged. Replace defective part(s) (refer to CONTINUOUSLY VARIABLE TRANSMISSION (CVT)).
 - Check if friction washer at one way clutch is worn. Replace friction washer (refer to CONTINUOUSLY VARIABLE TRANSMISSION (CVT)).
4. Check transmission lever and connecting rod.
 - Ball joint and/or ball joint nut is (are) loose. Retighten or replace the ball joint.
5. Check spring on shift shaft in gearbox.
 - Broken spring. Replace the spring (refer to GEARBOX).
6. Check for any mud intrusions.
 - CVT parts dirty. Clean all CVT parts.

COUPLING UNIT

Symptom: 4 WHEEL DRIVE INDICATION FAILS

1. Check contact screw on gear housing right side for damage and/or wear.
 - Shifting indicator switch pin is worn and/or damaged. Replace shifting indicator switch.
 - Contact is corroded and/or contact screw for wiring harness got loose. Clean contact surface and retighten contact screw with recommended torque.
 - Wiring harness has broken cable. Replace wiring harness.

Symptom: 4 WHEEL DRIVE DOES NOT ENGAGE OR DISENGAGE

1. Check actuator and/or actuator shifting fork for wear and/or damages.
 - Check if selector works properly. If so, check actuator.
 - If selector is out of specifications, check wires, connectors and/or replace selector.
 - Actuator shifting fork is worn out and/or damaged. Replace shifting fork of actuator.
 - Check function of actuator. Replace if actuator is not turning, refer to GEARBOX.
2. Check shifting sleeve splines and/or shifting fork for wear and/or damages.
 - Check sleeve shows damaged splines. Replace shifting sleeve (refer to GEARBOX).
 - Shifting fork is worn out and/or engagement pin is damaged. Replace shifting fork.

CVT

Symptom: UNUSUAL ACCELERATION BEHAVIOR

1. Check drive belt condition.
 - Belt is too narrow (drive belt engagement is higher in drive pulley).replace belt if width is less than specified.
2. Check lever condition on drive pulley sliding sheave and/or roller(s) on governor cup.
 - Lever(s) on drive pulley sliding sheave is (are) worn and/or damaged. Replace all levers

- at the same time (lever kit).
- Roller(s) is (are) worn and/or damaged. Replace governor cup assembly.
- 3. Check drive/driven pulley sliding sheave for free axial movement.
 - Sliding sheave is stuck. Replace damaged part(s).
- 4. Check condition of drive/driven pulley spring.
 - Drive pulley spring tension is too smooth and/or damaged. replace spring.
 - Driven pulley spring tension is too stiff. Replace spring.
- 5. Check if cam of driven pulley is worn.
 - Replace if out of specifications.
- 6. Check condition of fixed and sliding sheaves (drive and driven pulley).
 - Check surface of fixed and sliding sheaves (drive and driven pulley) for grooves or other damages.
- 7. Check valve adjustment.
 - Intake and/or exhaust valves are not adjusted correctly. Adjust valves.
- 8. Check engine condition.
 - Low engine compression.
- 9. Check ignition condition.
 - Faulty spark plug. Install new spark plug(s).
- 10. Check differentials operation.
 - Vehicle on Neutral is hard to move. Repair or replace defective part(s).

Symptom: ENGINE MAXIMUM RPM IS TOO HIGH AND VEHICLE TOP SPEED IS NOT REACHED.

1. Check drive/driven pulley area for contamination and/or water intrusion.
 - CVT area is contaminated with water, dirt or oil. Clean CVT system and replace damaged part(s).
2. Check drive/driven pulley spring tension.
 - Drive pulley spring tension is too stiff. Replace spring.
 - Driven pulley spring tension is too smooth and/or damaged. Replace spring.

Symptom: DRIVE PULLEY NOISE IN IDLE SPEED

1. Check slider shoes (drive pulley).
 - Worn slider shoes (increased clearance between governor cup and drive pulley sliding sheave). Replace all slider shoes at the same time (slider shoes kit).
2. Check driven pulley sliding mechanism (between driven pulley outer and inner sheave).
 - Mechanism is stuck and/or damaged. Replace driven pulley assembly.
3. Check roller(s) and/or levers for wear (located on sliding sheave of drive pulley).
 - Roller(s) on governor cup is (are) worn out and/or damaged. Replace governor cup assembly.
 - Lever(s) on drive pulley sliding sheave is (are) worn out and/or damaged. Replace all levers at the same time (lever kit).
4. Check drive pulley screw for torque.
 - Loose screw. Retighten screw with recommended torque.
5. Check one-way clutch condition on drive pulley sliding sheave.
 - Bearing(s) do(es) not move freely. Replace damaged part(s) and lubricate inside of one-way clutch.
 - Spring sleeve(s) inside one-way clutch is (are) worn out. Replace both sleeves and springs and lubricate inside of one-way clutch.
 - Spring(s) inside one-way clutch is (are) worn out. Replace both pins and springs and lubricate inside of one-way clutch.

Symptom: DRIVE PULLEY NOISE WHEN ACCELERATING/DECELERATING

1. Check if belt runs in dry condition.
 - Drive pulley area is wet/contaminated due to water/dirt intrusion. Clean driven pulley area and/or drain water out of CVT cover.
2. Check drive/driven pulley screw for torque.
 - Loose screw on drive pulley. Retighten screw with recommended torque.
3. Check cam and driven pulley fixed sheave for wear.
 - Cam and/or drive pulley fixed sheave out of wear limit and/or damaged. Replace damaged part(s).
4. Check torque gear fixed in driven pulley sliding sheave for wear.
 - Torque gear out of wear limit and/or damaged. Replace torque gear).
5. Check for foreign particles in CVT area (stones, dirt, etc.).
 - Small particles damaged belt and/or pulley surface(s). clean system and replace damaged parts.

Symptom: VIBRATIONS ORIGINATING FROM DRIVE PULLEY

1. Check tightening torque of drive pulley screw.
 - Moving sliding sheave. Retighten screw.
2. Check fixed sheave bushings.
 - Excessive gap between bushings and fixed sheave shaft, thus restraining sliding sheave movements. Replace fixed sheave assembly.
3. Check if slider shoes are present and/or placed in correct position.
 - Slider shoe(s) is (are) missing and/or damaged. Replace all slider shoes at the same time (slider shoes kit).

Symptom: VIBRATIONS ORIGINATING FROM DRIVEN PULLEY

1. Check fixed and sliding sheave bushings on driven pulley.
 - Excessive gap between bushings and CVT shaft, thus restraining sliding sheave movements. Replace fixed and/or sliding sheave of driven pulley, polish CVT shaft area with fine emery cloth and wipe clean with a cloth.

Symptom: PULLEYS DO NOT DOWN/UP SHIFT PROPERLY.

1. Check drive pulley bushings (cleanliness, wear, etc.)
 - Check items 1 and 2 of UNUSUAL ACCELERATION BEHAVIOR.
 - Bushings stick to fixed sheave pulley shaft. Clean or replace.
 - Spring seat sticks to sliding sheave pulley bushing. Clean system and/or replace sliding sheave pulley.
 - One-way clutch does not operate properly. Clean system and/or replace damaged part(s).
2. Check driven pulley spring tension.
 - Driven pulley spring tension is too weak or broken. Replace.
 - Driven pulley cam is worn or damaged. Replace.

Symptom: BELT GLAZED EXCESSIVELY OR HAVING BAKED APPEARANCE

1. Check if CVT air intake and/or outlet is clogged.
 - CVT area heats up due to contamination. Clean air intake and/or outlet from contamination.
 - Fans located on drive pulley is worn or damaged. Replace.
2. Check if pulley sheaves are clean.
 - Oil on pulley surfaces. Clean pulley sheaves and replace belt.
 - Water intrusion in CVT area. Find root cause and repair. Drain water and replace belt.

Symptom: BELT WORN EXCESSIVELY IN TOP WIDTH.

1. Check drive belt width.
 - Considerable wear. Replace belt if narrower than specified (refer to CONTINUOUSLY VARIABLE TRANSMISSION (CVT) OR TECHNICAL SPECIFICATIONS).
2. Check driver belt identification number.
 - Wrong type of belt. Replace belt with an appropriate drive belt.
3. Check for localized belt wear caused by belt slippage.
 - Localized wear. Replace belt.

Symptom: BELT DISINTEGRATION.

1. Check drive belt lifetime is exceeded..
 - Clean CVT system and rebuild with a new drive belt.
2. Check drive belt identification number.
 - Excessive belt speed. Using unspecified type of belt. Replace belt with proper type of belt.
3. Check if pulley sheaves are clean.
 - Oil on pulley surfaces. Clean pulley surfaces with fine emery cloth and wipe clean using pulley flange cleaner and a cloth.
 - Drive/driven pulley sheaves are damaged through stones inside CVT area. Clean pulley surfaces with fine emery cloth, wipe clean with a cloth or replace drive/driven pulley sheaves and belt.

Symptom: BACK BETWEEN COGS

1. Check drive belt condition.
 - Considerable use, belt wearing out. Replace.
 - Brittle belt condition through aging. Replace belt.

ENGINE GENERAL

Symptom: ENGINE CRANKS BUT FAIL TO START

1. Check if spark plug connectors fit on spark plugs (refer to IGNITION SYSTEM).
2. Check spark plugs.
 - Define spark plugs (no spark) or wrong spark plug gap. Readjust gap and clean spark

- plugs or replace.
- 3. Check for fuel on spark plugs.
 - Flooded engine (spark plugs wet when removed). Activate engine drowned mode and crank engine with rags over the spark plug holes.
- 4. Check battery voltage.
 - Battery is discharged and starter works not properly. Charge battery.
- 5. Check fuel level in fuel tank and fuel pressure. Ensure fuel pump was not disabled.
 - Low or no fuel pressure. Replace defective part(s).
- 6. Check fuel injectors.
 - Plugged or faulty injector(s). Replace defective part(s).
- 7. Check idle bypass valve.
 - Stuck or defective..
- 8. Check encoder wheel.
 - Bent tooth. Refer to MAGNETO SYSTEM.
- 9. Check engine compression.
 - Insufficient engine compression. Replace defective part(s).
- 10. Check fault codes in B.U.D.S. system.
 - Check if electrical actuator(s) is/are defective. Replace defective part(s) (refer to COMPONENT INSPECTION AND ADJUSTMENT).

Symptom: ENGINE DOES NOT START

1. Electrical problem.
 - Determine if the electrical system works correctly (fuse(s), battery, wiring harness, etc.). refer to IGNITION SYSTEM.
2. Problem with fuel system (carburetor, fuel pump, hoses, etc.).
 - Clean, inspect, repair or replace defective parts. Replace defective part(s).
3. Check engine compression.
 - Insufficient engine compression. Replace defective parts.
 - Valve seat worn and/or damaged. Repair by performing valve guide procedure (refer to CYLINDER AND HEAD). Readjust valve clearance.
4. Internal engine problem.
 - Overhaul engine to find defective parts. Refer to the appropriate section in ENGINE.

Symptom: ENGINE HARD TO START

1. Check idle bypass valve.
 - Stuck or defective. Refer to ENGINE MANAGEMENT.
2. Check closed throttle and idle actuator with B.U.D.S.
 - Wrong TPS zero setting/idle bypass valve reset. Refer to ENGINE MANAGEMENT.
3. Check engine compression.
 - Wrong adjustment (likely too tight). Refer to ENGINE MANAGEMENT.
4. Check engine compression.
 - Insufficient engine compression. Replace defective part(s) refer to LEAK TEST.
5. Verify spark plug condition.
 - Defective, improperly set, worn out, fouled. Identify source of problem and correct. Replace.
6. Check fuel level in fuel tank and fuel pressure.
 - Low or no fuel pressure. Replace defective part(s) refer to FUEL TANK AND FUEL PUMP.
7. Check CAPS (camshaft position sensor).
 - Defective sensor/wiring. Refer to ENGINE MANAGEMENT.

Symptom: ENGINE SUDDENLY TURNS OFF

1. Perform engine leak test.
 - Damaged head gasket and/or seal and/or leaking inlet/exhaust valve(s). replace and/or repair defective parts.
2. Check spark plugs condition and/or gap.
 - Fouled spark plugs or wrong spark plug gap. Readjust gap and clean spark plugs or replace..
3. Piston seizure.
 - Spark plugs heat range is too hot. Install spark plugs with appropriate heat range (refer to TECHNICAL SPECIFICATIONS).
 - Compression ratio is too high. Install genuine parts.
 - Poor oil quality. Use recommended oil.
 - Leaks at air intake manifold (engine gets too lean). Retighten screws or replace air intake manifold gasket.

- Snow/water intrusion through intake system into combustion chamber. Clean intake system and replace defective part(s).
4. Melted and/or perforated piston dome; melted section at ring end gap.
 - Spark plugs heat range is too hot. Install recommended spark plugs (refer to TECHNICAL SPECIFICATIONS).
 - Coolant less than recommended level (engine gets too hot). Repair cooling circuit and/or refill with recommended liquid.
 - Poor quality and/or wrong fuel. Clean from contamination and use appropriate fuel (refer to TECHNICAL SPECIFICATIONS).
 5. Piston color is dark due to seizure on intake and exhaust side.
 - Cooling system leaks and lowers coolant level. Tighten clamps or replace defective parts. Add antifreeze in cooling system until appropriate level s reached. Replace damaged parts.
 6. Cracked or broken piston.
 - Cracked or broken piston due to excessive piston/cylinder clearance or engine overheating. Replace piston. Check piston/cylinder clearance (refer to CYLINDER AND HEAD).
 7. Check piston rings and cylinder surface for grooves.
 - Poor oil quality. Use recommended oil.
 - Contamination through engine intake. Replace defective part(s) and use new air filter.
 8. Check crankshaft, rocker arms movement.
 - Oil pump failure due to lack of oil. Repair and replace defective parts and use new recommended oil.
 - Oil contamination due to clogged oil filter/oil strainer. Replace oil and oil filter at the same time, replace defective part(s).
 9. Check valve springs exhaust/intake.
 - Broken valve spring damages the cylinder head, valve(s), rocker arm(s), piston, piston rings and connecting rod. Replace defective part(s).
 10. Check if fuel supply is sufficient.
 - Low fuel level.
 - Clogged fuel filter or fuel injector filter.
 - Fuel line is contaminated and/or bent. Clean and/or replace defective part(s).

Symptom: ENGINE BACKFIRES

1. Check spark plugs.
 - Carbon accumulation caused by defective spark plugs. Replace spark plugs.
2. Check leakage on intake manifold.
 - Air leak on intake system. Retighten screws and/or replace intake manifold gasket.
3. Check exhaust air leaking.
 - Exhaust gasket is leaking. Retighten screws and/or replace exhaust gasket.
4. Check intake valve(s) for leaking.
 - Intake valve(s) is (are) leaking. Repair or replace valve(s).
5. Check if fuel supply is sufficient.
 - Fuel line is contaminated and/or bent (engine gets lean). Clean and/or replace defective part(s).
6. Check engine ground.
 - Poor engine ground. Clean.

Symptom: ENGINE DOES NOT OFFER MAXIMUM POWER AND/OR DOES NOT REACH MAXIMUM OPERATING RPM

1. Check spark plugs condition and/or gap.
 - Fouled spark plugs or wrong spark plug gap. Readjust gap and clean spark plugs or replace.
2. Check spark plugs type.
 - Improper spark plugs heat range. Install recommended spark plugs (refer to TECHNICAL SPECIFICATIONS).
3. Perform engine leak test.
 - Damaged head gasket and/or seal and/or leaking intake/exhaust valve(s). replace and/or repair defective parts.
4. Check for water in fuel (wrong fuel).
 - There is water in fuel or wrong fuel. Drain fuel system, search for leakage and refill it with appropriate fuel.
5. Check engine compression.
 - Worn piston(s) and/or piston ring(s). Replace defective part(s).
6. Check fuel pressure.

- Low fuel pressure. Perform fuel pressure test (refer to FUEL SYSTEM).
- 7. Check air intake system.
 - Air filter is clogged due to contamination. Replace air filter.
- 8. Check if EMS (engine management system) is in limp home mode. Check fault codes in B.U.D.S. system.
 - Check if electrical actuator(s) is/are defective. Replace defective part(s).
- 9. Check drive belt.
 - Worn. Replace belt if its width is less than specified.

Symptom: HIGH ENGINE OPERATING TEMPERATURE

1. Check if cooling system shows any failure (see COOLING SYSTEM).
 - System is leaking. Repair and/or replace damaged part(s).
2. Check function of lubrication system (see LUBRICATION SYSTEM).
 - Lubrication is not working properly. Repair and/or replace damaged part(s).
3. Check condition and heat range of spark plugs.
 - Melted spark plug tip or inadequate heat range. Replace.
4. Check air leakage on engine intake.
 - Leakage causes overheating. Replace/repair damaged part(s).
5. Check air inlet and outlet of the CVT cover.
 - Air circulation is clogged (overheating). Clean air circulation from contamination.
 - Drive belt worn and/or damaged. Replace belt with an appropriate drive belt (refer to TECHNICAL SPECIFICATIONS).